



Instruction Manual

WPX3400
Pressure Washer



CONGRATULATIONS ON PURCHASING A WESTINGHOUSE PORTABLE PRESSURE WASHER

Thank you for purchasing a Westinghouse portable pressure washer. It is a high-quality power product that will provide many years of safe and reliable service if properly operated and maintained.

DANGER



This manual contains important instructions for operating the pressure washer. For your safety and that of others, be sure to read this manual thoroughly before operating the pressure washer. Failure to properly follow all instructions and precautions could cause you or others to be seriously injured or killed. This manual should be considered a permanent part of the pressure washer and should remain with it if resold.

For Your Records

Date of Purchase: _____

Pressure Washer Model Number: _____

Purchased From: _____

Pressure Washer Serial Number: _____

Purchase Receipt: Please retain your tax invoice or purchase receipt to ensure warranty coverage.

DISCLAIMERS

All instructions, illustrations and specifications in this manual are based on the latest information available at the time of publishing. The illustrations used in this manual are intended as representative reference views only. Moreover, because of our continuous product improvement policy, we may modify information, illustrations or specifications to explain or exemplify a product, service or maintenance improvement. We reserve the right to make any change at any time without notice. Your pressure washer may differ slightly from the models pictured, including optional accessories.

ALL RIGHTS RESERVED

No part of this publication may be reproduced or used in any form by any means – graphic, electronic or mechanical, including photocopying, recording, taping or information storage and retrieval systems – without the written permission of Westinghouse Outdoor Power Equipment.

UPDATES

The latest Instruction Manual for your Westinghouse pressure washer can be found under the Downloads tab on our website at www.westinghouseoutdoorpower.com.au

CONTENTS

SAFETY	1
SAFETY DEFINITIONS.....	1
SAFETY SYMBOLS.....	1
GENERAL SAFETY RULES.....	2
WORKPLACE SAFETY RULES.....	4
SAFETY LABELS.....	4
UNPACK	5
UNPACK THE CARTON	5
Accessories and Components	5
ASSEMBLE	6
WHEELS.....	6
HANDLE	6
Spray Gun Holder.....	7
Spray Lance Rest.....	7
Spray Nozzles and Cleaning Tool.....	7
Spray Gun and Lance	7
Pressure Hose.....	8
Spray Nozzle	8
FEATURES	9
MAIN PRESSURE WASHER COMPONENTS.....	9
OPERATION	11
PREPARE FOR OPERATION.....	11
Before Starting the Pressure Washer	11
ADD INITIAL ENGINE OIL AND FUEL.....	11
Add Engine Oil	11
Add Fuel	11
ADD DETERGENT.....	12
CONNECT THE WATER SUPPLY	13
START THE PRESSURE WASHER.....	13
STOP THE PRESSURE WASHER	15
Normal Operation	15
During an Emergency	15
SPRAY NOZZLES	15
Use the Spray Nozzles.....	15
Change the Spray Nozzle	15
Spray Nozzle Selection	16
PRESSURE WASHING TIPS.....	17
Applying Detergent.....	17
Pressure Washing or Rinsing.....	17
After Each Use	17
TRANSPORT THE PRESSURE WASHER.....	18
MAINTENANCE	19
MAINTENANCE PRECAUTIONS	19
MAINTENANCE SCHEDULE	20
BEFORE ANY MAINTENANCE.....	20
ENGINE OIL.....	21
Engine Oil Specification	21
Check Engine Oil.....	21
Add Engine Oil	21
Change Engine Oil	22
AIR FILTER.....	22
Clean the Air Filter.....	23
Replace the Air Filter Elements.....	24
FUEL SYSTEM	24

CONTENTS

Clean the Fuel Strainer	24
Fuel Sediment Cup.....	24
Drain the Fuel.....	25
SPARK PLUG.....	26
Spark Arrestor	27
CLEAN THE PRESSURE WASHER.....	28
WATER SYSTEM.....	28
Water Inlet Screen.....	28
High Pressure Hose	28
Spray Gun	29
Spray Nozzles	29
Detergent System.....	29
Water Pump	30
LONG-TERM STORAGE.....	31
Storage for 1 – 3 Months.....	31
Storage for Greater Than 3 Months	31
Remove from Storage	32
DISMANTLE AND DISPOSE	32
TROUBLESHOOTING.....	33
SPECIFICATIONS.....	37
WPX3400 WIRING DIAGRAM	38
WARRANTY	39
WARRANTY AGAINST DEFECTS	39
Proof of Purchase.....	39
Warrantor.....	39
Warranty Conditions.....	39
NOTES.....	40

SAFETY

SAFETY DEFINITIONS

The words DANGER, WARNING, CAUTION and NOTICE are used throughout this manual to highlight important information. Be certain that the meanings of these alerts are known to all who work on or near the equipment.



This safety alert symbol appears with most safety statements. It means attention, become alert, your safety is involved! Please read and abide by the message that follows the safety alert symbol.

DANGER

Indicates a hazardous situation which, if not avoided, will result in death or serious injury.

WARNING

Indicates a hazardous situation which, if not avoided, could result in death or serious injury.

CAUTION



Indicates a hazardous situation which, if not avoided, could result in minor or moderate injury.



NOTICE

Indicates a situation which, if not avoided, could cause damage to the equipment, personal property or the environment, or cause the equipment to operate improperly.



NOTE: Indicates a procedure, practice or condition that should be followed in order for the equipment to function in the manner intended.



SAFETY SYMBOLS



Symbol	Description
	Safety Alert Symbol
	Asphyxiation Hazard



Symbol	Description
	Burn Hazard
	Burst / Pressure Hazard
	Corrosive Liquid Hazard
	Electrical Shock Hazard
	Explosion Hazard
	Fall Hazard
	Fire Hazard
	Flying Objects Hazard
	High Pressure Water Piercing Hazard
	High Pressure Water Steam Hazard
	Lifting Hazard
	Slippery Surface Hazard
	Read Manufacturer's Instructions
	Don't Leave Tools Around
	Wear Personal Protective Equipment (PPE)
	Read Safety Messages Before Proceeding

GENERAL SAFETY RULES





 DANGER	
	<p>Never operate the pressure washer in an enclosed area. Engine exhaust contains poisonous carbon monoxide.</p> <p>Only operate the pressure washer outside and far away from windows, doors and vents.</p>



 WARNING	
 	<p>Petrol fuel liquid and vapours are extremely flammable and explosive under certain conditions.</p> <ul style="list-style-type: none"> • Always refuel the pressure washer outdoors, in a well-ventilated area. • Never remove the fuel cap while the engine is running. • Never refuel the pressure washer while the engine is running. Always turn engine off and allow it to cool before refuelling. • Only fill fuel tank with unleaded petrol. • Keep away from sparks, open flames or other forms of ignition such as matches, cigarettes, CB radios and mobile phones when refuelling. • Never overfill the fuel tank. Leave room for fuel to expand. Overfilling the fuel tank can result in a sudden overflow of spilt fuel coming into contact with hot surfaces. Spilt fuel can ignite. If fuel is spilled on the pressure washer, wipe it up immediately and dispose of rags properly. Allow area of fuel spill to dry before operating the pressure washer. • Wear eye protection while refuelling. • Check for fuel leaks after refuelling. • Never operate the engine if a fuel leak is discovered. • Never operate in a hazardous location. • Keep the pressure washer away from combustible materials while the engine is running.



 WARNING	
 	<p>Never use fuel as a cleaning agent. Store any fuel containers in a well-ventilated area, away from any combustibles or source of ignition.</p>

 WARNING	
 	<p>The high pressure water stream can penetrate skin and its underlying tissues, which can result in amputation or other serious injury. The spray gun can entrap high pressure water, even when engine is stopped and water is disconnected. High pressure water leaks caused by loose fittings or damaged / worn hoses can result in piercing injuries. Do not treat fluid injection or piercing as a simple cut. Consult a physician immediately.</p> <ul style="list-style-type: none"> • Never aim spray gun at people, animals or plants. Direct spray away from oneself and others. • Never place hands in front of nozzle while spraying. • Always point spray gun in a safe direction while spraying and when relieving entrapped high pressure water after stopping engine. • Do not allow children to operate the pressure washer. Keep children and pets away while spraying. • Never leave the spray gun unattended while engine is running. • Never secure the spray gun trigger in its open position. • Do not touch nozzle while spraying. • Never attempt to repair the high pressure hose. Always replace it. • Never repair leaking high pressure connections with sealant of any kind. Always use factory recommended repair parts. • Never hold onto the high pressure hose or fittings during operation.

SAFETY

 WARNING	
	<ul style="list-style-type: none"> Do not allow the high pressure hose to contact muffler or other hot surfaces. Always ensure that the spray gun, nozzles and hoses are correctly attached and in good working order. Never use the spray gun if its trigger lock is not working properly. Only use the supplied spray gun, pressure hose and connections with pressure ratings equal to or greater than the machine's pressure rating. Never attach or remove spray gun or pressure hose while system is pressurised.
	Never aim water spray at or in the vicinity of any electrical power source. Contact with a live electrical source can cause electric shock, burn or explosion / ignition of the fuel.
 	<p>Kickback / recoil from the spray gun can cause you to fall.</p> <ul style="list-style-type: none"> Use of the pressure washer can create slippery conditions underfoot. The operating area of this equipment should ideally have adequate drainage to reduce the possibility of a fall due to slippery surfaces. Otherwise, use a floor squeegee to remove excess water ponding. Be extremely careful if using the pressure washer from a ladder, scaffolding or any other elevated access device. Use both hands to firmly grasp the spray gun while in use to avoid injury from high pressure kickback upon pulling the trigger.
	Use only biodegradable, non-flammable and non-toxic pressure washer detergent added via the detergent tank and not pre-mixed into the low pressure water supply. Do not use any acid, alkali, flammable solvent, insecticide, poison or other harmful / toxic substance that can cause physical injury by contact, ingestion or inhalation.

 WARNING	
 	Always wear safety goggles that comply with AS/NZS 1337 when operating or in the vicinity of the pressure washer. Hearing protection, closed shoes and long trousers should also be worn.
	Always remove any tools or other service equipment used during maintenance before operating the pressure washer.

 CAUTION	
	Hot surfaces on the engine and pump can cause burns. Do not touch while the engine is running. Allow to cool afterwards before touching.

NOTICE	
<p>Never operate the pressure washer with damaged or missing parts.</p> <p>Never modify any feature or component of the pressure washer.</p> <p>Never spray at glass when using the high pressure red (0°) nozzle. High pressure spray may damage fragile items.</p> <p>Do not exceed rated pressure when operating the pressure washer.</p> <p>Never move the pressure washer by pulling on any hoses. Always use the handle to move it around.</p> <p>Do not use or store the pressure washer in freezing conditions at or below 0°C. Check that no ice has formed in or on any part of the device.</p> <p>Remove the protective shipping caps, if fitted, from the pressure pump's water inlet and outlet connections before use.</p> <p>Ensure that the water supply is connected and turned on before starting the engine. Damage to the pump will occur otherwise, which is not covered by warranty.</p> <p>The water supply must be capable of delivering a flow rate of 15 L/min at a positive pressure to the pump inlet. Do not draw or siphon from a standing water supply; preferably connect to a pressurised water supply. The water temperature must not exceed 40°C (104°F).</p>	

NOTICE

Do not install a one-way valve (check valve) or vacuum breaker at the pressure washer's water inlet. Allow at least 3 m (10 ft) of unrestricted supply hose length between any such device and the water inlet. Otherwise damage may occur to the pump, which is not covered by warranty.

WORKPLACE SAFETY RULES

The Westinghouse WPX3400 pressure washer is intended for domestic use only by consumers in normal residential and recreational applications. It is not intended for commercial use by workers in business applications.

If used at a workplace nonetheless, the pressure washer must also be operated and maintained in accordance with (a) Australian Standard AS 4233 and (b) the Guide for Managing Risks from High Pressure Water Jetting as published online by Safe Work Australia. The pressure washer is rated as a Class A pressure water jetting system.

SAFETY LABELS



The safety labels have specific positions and must be replaced if they are unreadable, damaged or missing.



Figure 1 Safety Labels

UNPACK

UNPACK THE CARTON

⚠ CAUTION	
	Always have assistance when lifting the pressure washer. The pressure washer is heavy; lifting it can cause bodily harm.
	Avoid cutting on or near staples to prevent personal injury.

1. Carefully cut the packing tape on top of the carton.
2. Fold back top flaps to reveal the Instruction Manual. Remove the manual and save it for reference.
3. Carefully cut down along the four vertical corners of the carton and fold the sides flat onto the ground.
4. Leave the pressure washer chassis on the base of the carton but locate and remove the other components and accessories.
5. Proceed with assembly of the pressure washer (see Assembly).
6. Lift or wheel the assembled pressure washer off the carton and then recycle or dispose of the packaging materials properly.

Accessories and Components

Check the accessories and components against those shown in Figure 2. If any items are missing, please contact your Westinghouse Outdoor Power Equipment dealer.

1. Pressure Washer Chassis
2. Handle
3. High Pressure Hose
4. Spray Gun
5. Lance
6. Spray Nozzles (x 5)
7. Nozzle Cleaning Tool
8. Spray Gun Holder and Fasteners (x 2)
9. Lance Rest and Fasteners (x 1)
10. Wheels (x 2)
11. Axles (x 2)
12. R-Clips (x 2)
13. Bottle of Engine Oil (600 ml) with Funnel Tip
14. Instruction Manual



Figure 2 Accessories and Components

CAUTION



Never lift the pressure washer without assistance. The pressure washer is heavy and lifting without assistance can result in personal injury.



Never use the handle as a lifting point to support the entire weight of the pressure washer. Only use the handle to lift the pressure washer while simultaneously lifting it from underneath the chassis frame. The handle can also be used to move the compressor around on its wheels.

NOTICE

Assembling the pressure washer will require tipping the unit over onto one of its sides and then the other. Make sure all engine oil and fuel are drained from the unit prior to assembling.

Once assembled, the wheels are not intended for towing the pressure washer either on or off-road. The wheels are designed for use on this pressure washer only.

Never tip the pressure washer over after it has been fully assembled and filled with oil and fuel.

WHEELS

1. Place pressure washer chassis on a flat surface if not already on the base of its shipping carton after unpacking.
2. Place a piece of cardboard or other soft material on the ground and tip the pressure washer over onto its side. This should protect the frame from being scratched and stop it from sliding about on the ground.
3. Insert an axle through one of the wheels from the recessed hub side. Then insert the protruding axle through the axle bracket on the frame under the engine.
4. Insert the straight leg of one R-clip through the hole in the end of the axle as shown in Figure 3.
5. Repeat steps 2, 3 and 4 using the other wheel, axle and R-clip.

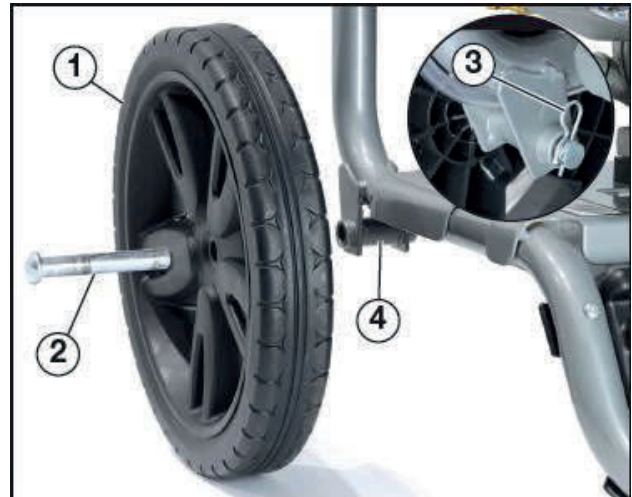

- | | |
|----------|----------------|
| 1. Wheel | 3 R-Clip |
| 2. Axle | 4 Axel Bracket |

Figure 3 Attaching Wheel to Frame

HANDLE

1. Position the handle with its connecting female tube ends located vertically above the male tube ends protruding upwards from the pressure washer chassis frame. See Figure 4.
2. Lower the female tube ends onto the male tube ends. Push in the spring-loaded locking buttons and keep lowering until the locking buttons engage with the holes in the female tube ends.

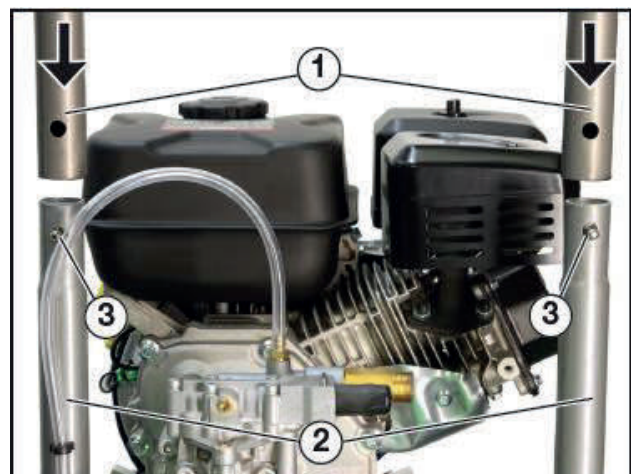

- | |
|-------------------|
| 1. Handle |
| 2. Frame |
| 3. Locking Button |

Figure 4 Attaching Handle to Frame

ASSEMBLE

Spray Gun Holder

Tools required – 4 mm hex key and 10 mm socket wrench.

Attach the spray gun holder to the handle using the supplied fasteners as shown in Figure 5.

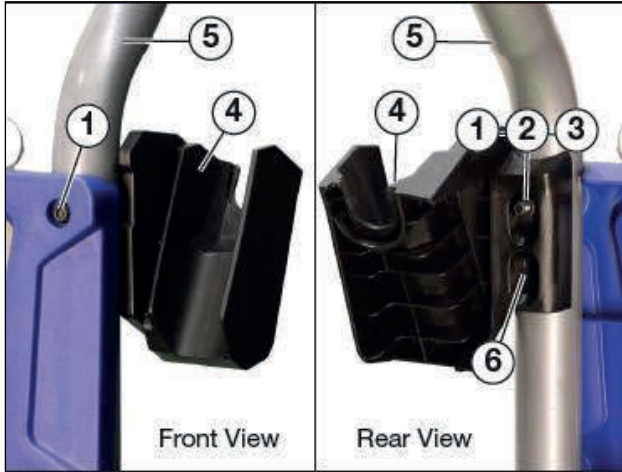

- | | |
|-------------|---------------------|
| 1. Hex Bolt | 4. Spray Gun Holder |
| 2. Nut | 5. Handle |
| 3. Washer | 6. Push Fit Rivet |

Figure 5 Attaching Spray Gun Holder to Handle

Spray Lance Rest

Attach the spray lance rest to the frame using the supplied fasteners as shown in Figure 6.

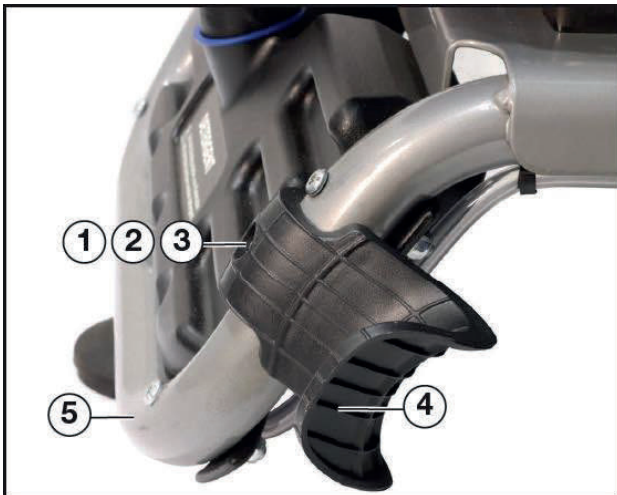

- | | |
|-------------|---------------------|
| 1. Hex Bolt | 4. Spray Lance Rest |
| 2. Nut | 5. Frame |
| 3. Washer | |

Figure 6 Attaching Spray Lance Rest to Frame

Spray Nozzles and Cleaning Tool

Insert the spray nozzles and the nozzle cleaning tool into their respective marked positions on the hose and nozzles holder as shown in Figure 7.



1. Spray Nozzle
2. Nozzle Cleaning Tool
3. Hose and Nozzles Holder

Figure 7 Storing Spray Nozzles and Cleaning Tool

Spray Gun and Lance

1. Check that the two O-rings on the spray gun - lance threaded coupling are intact and not damaged and then lubricate them by moistening with water or applying silicone lubricant.
2. Assemble the coupling and tighten the connection firmly by hand. It is a standard right-handed thread. See Figure 8.



1. Spray Gun
2. Lance
3. O-Ring

Figure 8 Assembling Spray Gun and Lance

Pressure Hose

1. Check that the O-ring on each of the two pressure hose threaded couplings is intact and not damaged and then lubricate them both by moistening with water or applying silicone lubricant.
2. Connect one coupling to the high pressure pump outlet and tighten the connection firmly by hand. See Figure 9.

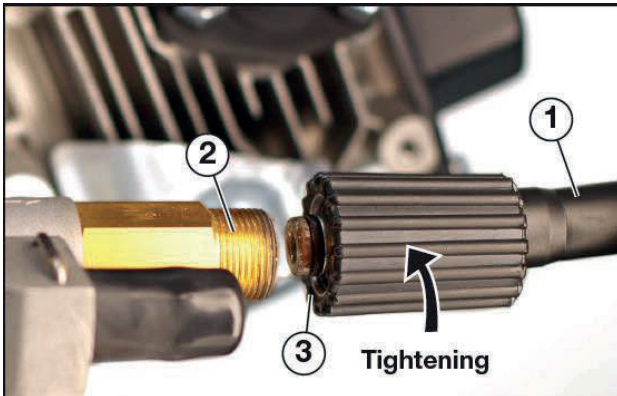

1. Pressure Hose
2. High Pressure Pump Outlet
3. O-Ring

Figure 9 Connecting Pressure Hose to Pump Outlet

3. Connect the other coupling to the spray gun inlet and tighten the connection firmly by hand. See Figure 10.

NOTE: The two pressure hose threaded couplings are identical and either one can be connected to the pump outlet or spray gun. Both are standard righthanded threads.



1. Pressure Hose
2. Spray Gun Inlet
3. O-Ring
4. Spray Gun

Figure 10 Connecting Pressure Hose to Spray Gun

Spray Nozzle

1. Select the desired nozzle for the cleaning application.
2. Apply the trigger lock on the spray gun by rotating it away from the trigger and locking it into position within the detent on the hand grip as shown in Figure 11. Note: Push the trigger forwards for ease of applying the trigger lock if necessary.

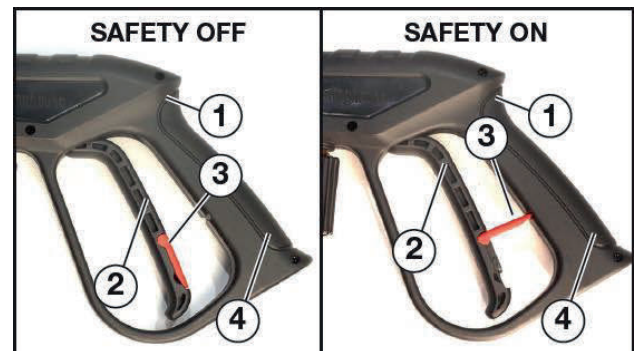

1. Spray Gun
2. Trigger
3. Trigger Lock
4. Hand Grip

Figure 11 Operating the Trigger Lock

3. Pull back the collar on the lance's quick connect coupling to its limit, insert the spray nozzle fully and then pull the collar forward if it hasn't already snapped back forward by spring action. Tug on the spray nozzle to ensure that it is securely locked into the coupling. See Figure 12.

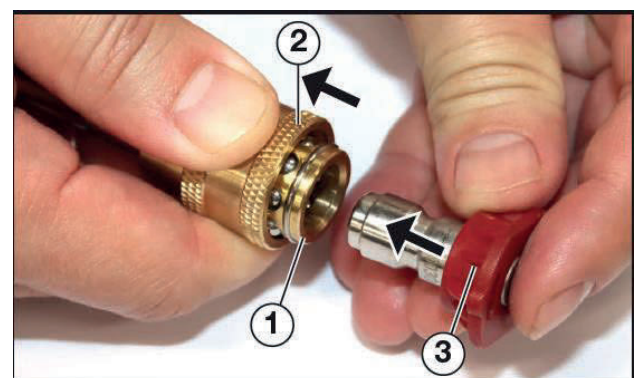

1. Lance Outlet Quick Connect Coupling
2. Locking Collar
3. Spray Nozzle

Figure 12 Installing the Spray Nozzle

4. Release the trigger lock on the spray gun by rotating it into its stowed position on the rear of the trigger as shown in Figure 11. Note: Push the trigger forwards for ease of releasing the trigger lock if necessary.

FEATURES

MAIN PRESSURE WASHER COMPONENTS





Figure 13 Main Pressure Washer Components



MAIN PRESSURE WASHER COMPONENTS

1. Spray Gun: Controls the application of high pressure water or low pressure detergent and water mixture onto the surface being cleaned. Includes an on / off trigger with safety lock.
2. Lance: Rigid extension between the spray gun and the spray nozzle. Includes a quick-change coupling for holding the spray nozzle.
3. Spray Nozzles: Control the velocity and pattern of the discharge spray for various cleaning applications.
4. High Pressure Hose: Connection between the water pump outlet and the spray gun inlet.
5. Pump: Moves water from the inlet to the spray gun at the required pressure and flow rate.
6. High Pressure Outlet: Connection for the high pressure hose.
7. Water Inlet: Connection for water supply from a garden hose.
8. Unloader Valve: Controls the pump output pressure and automatically switches the flow to recirculating while idling without spraying.
9. Thermal Relief Valve: Protects the pump from internal damage by automatically discharging water if it reaches 60°C.
10. Detergent Tank: Stores detergent that can be automatically diluted with water and sprayed at low pressure using the detergent nozzle.
11. Detergent Siphon Tube: Connection between the detergent tank and the pump.
12. Nozzle Cleaning Tool: Use to clean any foreign material clogging the spray nozzle orifice.
13. Hose and Nozzles Holder: Provides onboard storage for the pressure hose, nozzles and nozzle cleaning tool when not in use.
14. Engine: Provides the power to drive the pump.
15. Fuel Tank: Stores unleaded petrol to run the engine.
16. Air Filter: Two-stage system that filters out dust from the intake air to protect the engine.
17. Muffler and Spark Arrester: Reduce engine exhaust noise and prevent the emission of hot exhaust particles.
18. Engine Control Switch: Use to turn the engine on or off.
19. Recoil Starter: Pull on the handle to start the engine.
20. Fuel Valve Lever: Turns fuel supply to the engine on or off.
21. Choke Lever: Adjusts the fuel-air mixture supplied to the engine for ease of cold starting.
22. Oil Fill Plug & Dipstick: Access to add oil, check the oil level or extract oil with a vacuum pump.
23. Oil Drain Plug: Access to drain oil by gravity.
24. Handle: Use to move the pressure washer around on its wheels.
25. Frame: Supports all the pressure washer components.
26. Baseplate: Mounting for the engine and pump.
27. Wheels: Provide mobility over all terrain.
28. Identification Label: Model and serial number information for after-sales product support.

OPERATION

PREPARE FOR OPERATION

 DANGER	
<p>Using petrol-powered equipment indoors can kill you in minutes. Engine exhaust contains carbon monoxide. This is a poisonous gas you cannot see or smell.</p>	
	
<p>Never use inside a home or garage, even if doors and windows are open.</p>	<p>Only use outside and far away from windows, doors and vents</p>

 WARNING	
	<p>Always operate the pressure washer on a sufficiently level and sturdy surface that will prevent it from tipping over and causing a fuel or oil spill. Spilt fuel can ignite if it comes into contact with an ignition source such as a very hot engine surface.</p>



NOTICE	
<p>Do not operate the pressure washer on a surface with loose material such as sand or grass clippings that can block the engine's air filter or cooling vents.</p>	

Before Starting the Pressure Washer

Location Selection – Before starting the pressure washer, avoid exhaust and location hazards by verifying that the selected operating location:

- Is outdoors and well ventilated.
- Has adequate drainage and is sufficiently level and solid to prevent the pressure washer from tipping over.
- Is at least 1.8 m away from any building, other equipment or combustible material.
- Is not located near any windows, doors or vents of a building.



ADD INITIAL ENGINE OIL AND FUEL

 WARNING	
	<p>Filling the fuel tank while the pressure washer is running can cause fuel to spill and come into contact with hot surfaces that can ignite the fuel.</p>

Before starting the pressure washer, always check the engine oil and fuel levels.

After starting the pressure washer, it is not safe to add fuel to the fuel tank or engine oil to the engine while the engine is running or immediately after stopping while the engine and muffler are still hot.



Add Engine Oil

 WARNING	
	<p>Internal pressure can build up in the engine crankcase while the engine is running. Removing the oil fill plug while the engine is hot can cause hot oil to spray out of the crankcase and cause severe skin burns. Allow engine oil to cool for several minutes before removing the oil fill plug & dipstick.</p>

NOTICE	
<p>The pressure washer does not contain engine oil as shipped. Attempting to start the engine before adding engine oil can permanently damage internal engine components.</p>	

The pressure washer as shipped does not contain oil in the engine. You must add engine oil before starting the pressure washer for the first time. See Checking Engine Oil and Adding Engine Oil in the Maintenance section for instructions.

Add Fuel

 WARNING	
	<p>Never refuel the pressure washer while the engine is running.</p>
	<p>Always turn the engine off and allow the pressure washer to cool before refuelling.</p>

CAUTION



Avoid prolonged skin contact with fuel. Avoid inhalation of fuel vapours.

With the pressure washer switched off and stationary on a horizontal surface, check the fuel level in the tank visually by removing the fuel cap. It is good practice to always fill the fuel tank before operating the pressure washer.

Required Fuel – Use only unleaded petrol with an octane rating not less than 91 and ethanol content not greater than 10%. Where possible, it is preferable to use unleaded petrol (RON 91) or premium unleaded petrol (RON 95 or 98) and not an ethanol blend such as E10.

Obey the steps below to fill the fuel tank:

1. Stop the pressure washer, if running.
2. Allow the pressure washer to cool down until the muffler cover is cool to the touch.
3. Move the pressure washer to a flat surface.
4. Clean area around the fuel cap.
5. Remove the fuel cap by unscrewing it anticlockwise about 1/3 of a turn.
6. Slowly add fuel into the fuel tank. Be careful not to overfill the tank. The fuel level should not be higher than the bottom of the filler neck as indicated by the red-coloured marker (see Figure 14).
7. Replace the fuel cap by screwing it clockwise about 1/3 of a turn until it reaches the limit stop.

NOTE: For ease of replacing the fuel cap, check that the two notches in the top rim of the fuel strainer are aligned with the two notches in the fuel tank filler neck as shown in Figure 14.

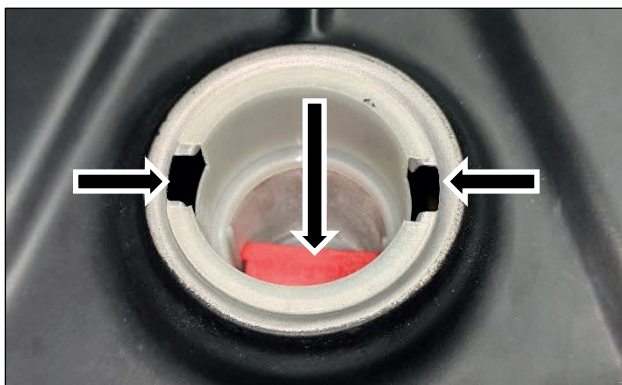

Figure 14 Fuel Strainer in the Aligned Position

ADD DETERGENT

WARNING



Use only biodegradable, non-flammable and non-toxic pressure washer detergent added via the detergent tank and not pre-mixed into the water supply. Do not use any acid, alkali, flammable solvent, insecticide, poison or other harmful toxic substance that can cause physical injury by contact, ingestion or inhalation.

Use only water-soluble liquid cleaning detergent that is approved by its manufacturer for spray application. Check the instructions to determine whether undiluted detergent can be added straight into the detergent tank or if it needs to be pre-mixed with water.

When applied via the pressure washer, the liquid drawn from the detergent tank is automatically diluted with water in a ratio of approximately 1 part detergent to 20 parts water before it is sprayed out through the detergent nozzle.

Fill the Detergent Tank – Follow the steps below to fill the detergent tank:

1. Stop the pressure washer, if running.
2. Open the cap on the detergent tank by pulling upwards on the cap's lift tab.
3. Slowly add detergent into the tank as shown in Figure 15 until the detergent level is about 5 cm below the top of the filler neck. Do not overfill.
4. Check that the breather hole in the top of the cap is unobstructed.
5. Replace the cap by pushing it downwards on top of the filler neck until it snaps closed.



Figure 15 Add Detergent

OPERATION

CONNECT THE WATER SUPPLY

⚠ WARNING	
	<p>Always wear safety goggles that comply with AS/NZS 1337 when operating or in the vicinity of the pressure washer. Hearing protection, closed shoes and long trousers should also be worn.</p>

NOTICE
<p>Do not start the engine without the water supply connected and turned on. Running the pump without water will damage it, which is not covered by warranty.</p> <p>The water supply must be capable of delivering a flow rate of 15 L/min at a positive pressure to the pressure washer inlet. Do not draw or siphon from a standing water supply; preferably connect to a pressurised water supply. The water temperature must not exceed 40°C (104°F).</p> <p>Ensure that the water inlet screen is in place and clear of any obstructions before attaching the water supply hose.</p> <p>Do not operate the pressure washer with a missing, damaged or obstructed inlet screen.</p>

1. Run water through the hose to clear out any debris that may be inside it.
2. Use the shortest water supply hose possible to minimise pressure drop and maximise flow rate.
3. The inlet water connection on the pressure washer is fitted with a standard 12 mm male quickconnect coupling onto which a garden hose with a standard 12 mm female quick-connect coupling can be attached. See Figure 16.

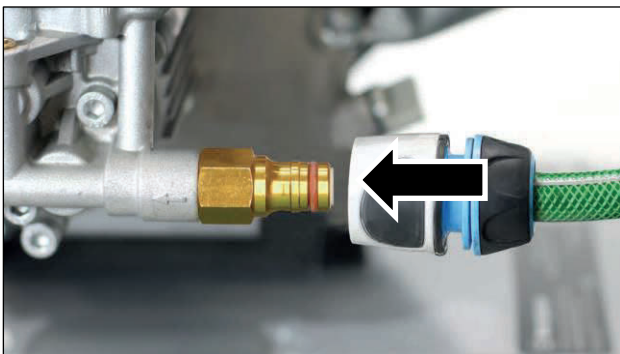



Figure 16 Attach Water Supply Hose

4. Turn on the water supply and check that there are no leaks.
5. Squeeze the trigger on the spray gun to bleed out any entrapped air in the hoses, pressure pump and spray gun. Continue until there is a steady stream of water coming out from the spray nozzle and then release the trigger.

START THE PRESSURE WASHER

⚠ DANGER	
	<p>Never operate the pressure washer in an enclosed area. Engine exhaust contains poisonous carbon monoxide. Only operate the pressure washer outside and away from windows, doors and vents.</p>

⚠ CAUTION	
	<p>Hot surfaces on the engine and pump can cause burns. Do not touch while the engine is running. Allow to cool afterwards before touching.</p>

NOTICE
<p>The pressure washer is equipped with a low oil shutdown switch. If the oil level is too low, the engine will shut down automatically and cannot be restarted until the oil is filled to the proper level.</p> <p>Be sure the engine has the proper oil level before using it. Failure to verify that the engine has the proper oil level could result in severe engine damage or shortened engine life.</p> <p>The pressure washer may move about due to vibration while operating on a hard surface and should preferably be operated on level ground where possible. Allow some slack in the water supply hose to allow for such movement and monitor the pressure washer to check that it does not tip over.</p> <p>The pressure pump is equipped with a thermal relief valve to protect it from overheating damage especially while idling for an extended period. Hot water may be ejected from the valve's discharge port to allow cooler supply water into the pump.</p>

Before starting the pressure washer, verify the following:

- The pressure washer is properly assembled.
- The engine is full of the correct type of oil.
- The fuel tank is full of the correct type of unleaded petrol.
- The detergent tank is full of the correct type of cleaning liquid, if required.
- All fluid connections are properly assembled and tight, including specifically:
 - Water supply hose to pressure pump inlet.
 - Pressure pump outlet to high pressure hose.
 - High pressure hose to spray gun inlet.
 - Spray gun outlet to lance inlet.
 - Lance outlet to spray nozzle.
- The water supply and high pressure hoses are not kinked or damaged.
- A water supply with adequate pressure and flow rate is connected and turned on.
- Low pressure water flows through the pressure pump and discharges continuously from the spray nozzle when the spray gun trigger is pulled.
- The pressure washer is located on a flat and solid surface outdoors in a well ventilated area at least 1.8 m (6 ft) away from any surrounding buildings.
- The outlet nozzle from the thermal relief valve is pointing straight down towards the ground.

When the above preparations have been completed, the pressure washer can be started as follows:

1. Rotate the trigger lock lever up into the SAFETY ON position as shown in Figure 11.
2. Turn the engine switch to the ON position as shown in Figure 17.

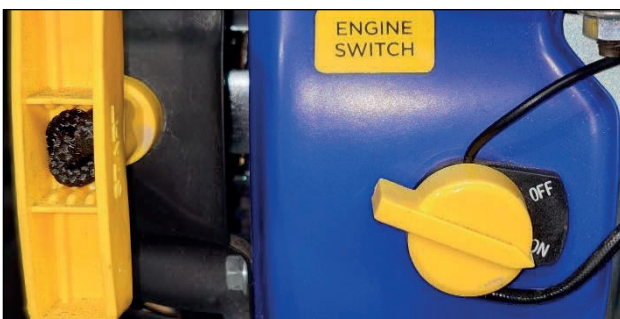

Figure 17 Engine Switch in the ON Position

3. Move the choke lever to the START position if the engine is cold (see Figure 18). To re-start a warm engine, leave the choke lever in the RUN position.



Figure 18 Choke Lever in the START Position

4. Move the fuel valve lever to the ON position as shown in Figure 19.

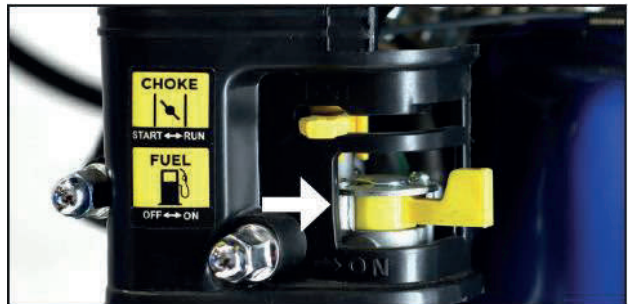

Figure 19 Fuel Valve Lever in the ON Position

5. Fuel Valve Lever in the ON Position Firmly grasp the recoil starter handle and pull it slowly until you feel increased resistance. At this point, pull it briskly up and away from the pressure washer (see Figure 20). Do not allow the starter handle to snap back against the engine, but instead return it gently to prevent starter damage. Do not allow the starter cord to rub against other parts of the pressure washer.



Figure 20 Recoil Starter Handle Operation

NOTE: After each attempt whereupon the engine fails to start, rotate the trigger lock lever down into the SAFETY OFF position (see Figure 11), aim the spray gun in a safe direction and squeeze the trigger briefly to

OPERATION

relieve the confined water pressure, return the trigger lock to the SAFETY ON position and then try to start the engine again.

6. As the engine starts to run and stabilise, gradually move the choke lever back to the RUN position.
7. Allow the engine to warm up for 30 seconds before using the pressure washing function.

STOP THE PRESSURE WASHER

Normal Operation

During normal operation, use the following procedure to stop the pressure washer:

1. Turn the engine switch to the OFF position.
2. Move the fuel valve lever to the OFF position.
3. Turn the water supply off.
4. Aim the spray gun in a safe direction and squeeze the trigger briefly to relieve any confined water pressure.
5. Disconnect the water supply hose from the pressure pump inlet.
6. Move the spray gun trigger lock to the SAFETY ON position.

During an Emergency

If there is an emergency and the pressure washer must be stopped quickly, turn the engine switch to the OFF position immediately.

SPRAY NOZZLES

Use the Spray Nozzles

NOTICE

Only use the spray nozzles that were originally supplied with the pressure washer. Using any other nozzles can adversely affect performance and may void the warranty. For replacement nozzles, please contact your Westinghouse Outdoor Power Equipment dealer.

The quick-change feature allows swapping between spray nozzles while the pressure washer is running provided that the spray gun trigger lock is in the SAFETY ON position.

Change the Spray Nozzle

⚠ WARNING



Always apply the trigger safety lock before changing the spray nozzle if the engine is running.

1. If the engine is not running, shut off the water supply, release the trigger safety lock on the spray gun by rotating the trigger lock lever down into the SAFETY OFF position, aim the spray gun in a safe direction, squeeze the trigger briefly to relieve the confined water pressure, and then return the trigger lock to the SAFETY ON position. See Figure 11.

If the engine is running, apply the trigger safety lock by rotating the trigger lock lever up into the SAFETY ON position as shown in Figure 11.

2. Pull back the collar on the lance's quick connect coupling to its limit and withdraw the installed spray nozzle by pulling it away from the lance as shown in Figure 21. Then release the locking collar. Store the removed spray nozzle in its marked location on the hose and nozzles holder.

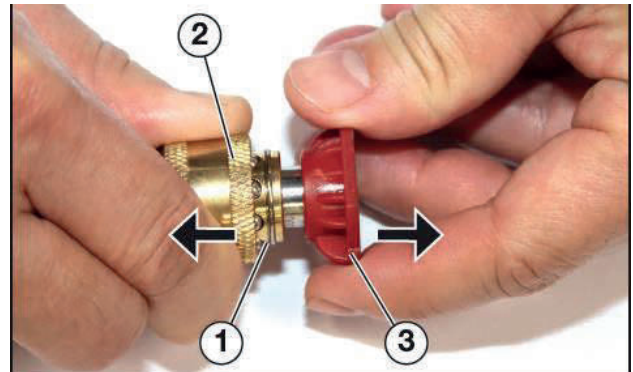

1. Lance Outlet Quick Connect Coupling
2. Locking Collar
3. Spray Nozzle

Figure 21 Remove the Spray Nozzle

3. Select the desired spray nozzle for the next cleaning application.
4. Pull back the collar on the lance's quick connect coupling to its limit and insert the spray nozzle fully as shown in Figure 12. Then pull the collar forward if it hasn't already snapped back forward by spring action. Tug on the spray nozzle to verify that it is securely locked into the coupling.
5. Turn on the water supply if it was shut off in Step 1 above.

Spray Nozzle Selection

Nozzle Colour	Spray Pattern	Spray Intensity	Use
Red		High	Intense cleaning of embedded or stubborn dirt and grime from very hard surfaces such as concrete, bricks and pavers. Removal of bitumen, gum, oil stains, paint, rust, wax, etc. Cleaning of high or hard-to-reach surfaces such as the second storey of a house when operating the pressure washer from ground level. NOTE: Never use to spray at glass or other delicate, fragile or soft surfaces. Never use on timber or exterior of cars, boats, RVs, etc.
Yellow		Medium to High	Strong cleaning of accumulated dirt, grease, grime, mildew, oil, bird droppings, etc. from durable surfaces on houses, fences, driveways, footpaths, patios, BBQs and so on.
Green		Medium	Moderate general-purpose cleaning of cars, boats, RVs, outdoor furniture and other durable surfaces amenable to pressure washing.
White		Low	Gentle cleaning or rinsing of all surfaces amenable to pressure washing. NOTE: Use caution when spraying at glass or other delicate, fragile or soft surfaces. Keep the spray nozzle at least 600 mm (2 ft) away.
Black		Very Low	Soft pre-wash application of detergent to loosen and breakdown stubborn dirt and grime. NOTE: Use only liquid detergent suitable for spray application.

Figure 22 Spray Nozzle Selection

OPERATION

PRESSURE WASHING TIPS

NOTICE

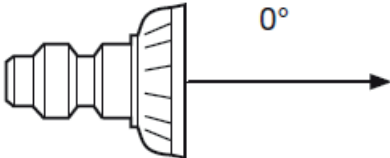
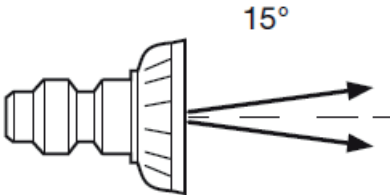
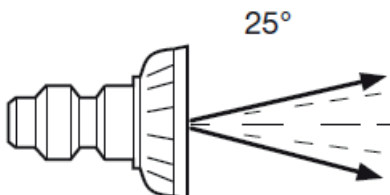
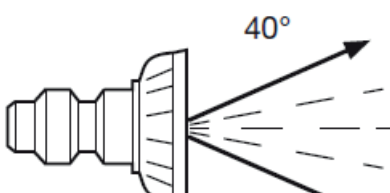
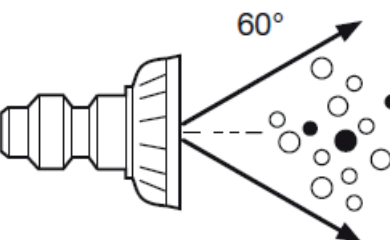
Damage may occur to the cleaning surface if the spray nozzle is held too close to it, especially when using the medium and high pressure nozzles.

If in any doubt about the durability of the surface to be cleaned, test wash a small inconspicuous area first and check for any adverse water erosion or penetration.

To avoid damage when cleaning tyres, do not use the red (0°) spray nozzle and do not spray closer than 30 cm (1 ft).

For best results, keep the spray nozzle between 15 to 20 cm (6 to 8 in) away from the surface being cleaned and hold the lance at a 45° angle as shown below.

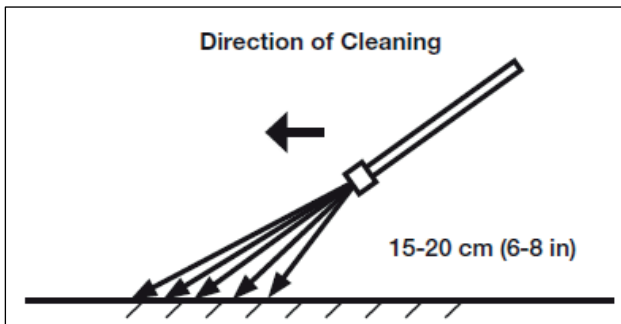

Figure 23 Spray Gun Lance Orientation

When beginning to pressure wash, start with the lance at least 60 cm (2 ft) away from the surface and then gradually move it closer if necessary while checking for any surface damage.

Applying Detergent

NOTICE

Use only the black (60°) very low pressure spray nozzle for applying detergent. The other higher pressure nozzles will not dispense detergent.

1. Install the black (60°) spray nozzle.
2. Check the detergent tank level and add detergent, if required, in accordance with the Adding Detergent instructions herein.
3. Turn on the water supply and start the pressure washer.
4. Apply the detergent to the surface working upwards from the bottom to the top in long, even and overlapping strokes.

5. Allow the detergent to soak in for a few minutes, but do not let it dry to prevent staining or streaking of the surface.

NOTICE

After using detergent, refill the detergent tank with clean water and spray it out using the black nozzle until the tank is empty. This flushes out the detergent and prevents it from drying out and clogging the detergent siphon tube and orifices.

Pressure Washing or Rinsing

1. Install either the red (0°), yellow (15°) or green (25°) spray nozzle for medium to high intensity washing. Or install the white (40°) spray nozzle for low intensity rinsing.
2. Wash or rinse the surface working downwards from the top to the bottom in overlapping strokes.
3. Always start with the lance at least 60 cm (2 ft) away from the surface and then gradually move it closer if necessary while checking for any water damage.

After Each Use

1. Switch off the pressure washer and turn off the water supply.
2. Add approximately 0.5 L of clean water into the detergent tank using the water supply hose to bring it to a level of about 1/3 full.
3. Install the black (60°) spray nozzle.
4. Turn on the water supply and start the pressure washer.
5. Pull the spray gun trigger continuously for several minutes until all of the water and traces of detergent have been siphoned out of the detergent tank and flushed through the pump, high pressure hose and spray gun. This can be monitored by observing the flow of liquid through the detergent siphon tube.
6. Switch off the pressure washer and turn off the water supply.
7. Point the spray gun in a safe direction and pull the spray gun trigger to relieve any confined water pressure.
8. Disconnect the water supply hose and the high pressure hose.
9. Drain any remaining water out of the pressure hose, spray gun and lance.
10. Coil up the pressure hose on its holder.

11. Engage the trigger lock on the spray gun and return it and the lance to their respective storage positions on the pressure washer.
12. While the pressure washer is switched off, pull the recoil starter handle five times to remove any remaining water from inside the water pump.
13. Allow the pressure washer to cool down if the engine is still hot to the touch.
14. Wipe down the pressure washer with a rag or chamois.
15. Store the pressure washer in a clean, dry and well ventilated place that is not subject to freezing temperatures.

TRANSPORT THE PRESSURE WASHER

Before transporting the unit, the pressure washer should be switched off and the fuel valve lever should be moved to the OFF position. Keep the pressure washer upright during transport to minimise the possibility of fuel leakage and preferably drain out the fuel prior to transport.

If the pressure washer has been operating, allow the unit to cool down before loading it onto the transport vehicle. The pressure washer's wheels are only intended for moving the unit around by hand. The wheels are not suitable for towing the pressure washer either on or off-road.







Use only the pressure washer's frame for lifting the unit or attaching any load restraints such as ropes or tiedown straps. Do not attempt to lift or secure the pressure washer by holding onto any of its other components.



Loose accessories such as the high pressure hose, spray gun and lance, spray nozzles and nozzle cleaning tool should be removed from the pressure washer and stowed securely for transport.



The handle can be removed, if necessary, to reduce the overall height of the pressure washer for ease of transport. The procedure to remove it is the reverse of that to install it as described in the ASSEMBLE instructions herein.

MAINTENANCE

MAINTENANCE PRECAUTIONS

 WARNING	
	Switch off the engine, turn off the water supply and disconnect the water supply hose before performing any maintenance on the pressure washer.
	Avoid accidentally starting the pressure washer during maintenance by removing the spark plug boot from the spark plug.
	Allow hot components to cool to the touch prior to performing any maintenance procedure.
	Internal pressure can build in the engine crankcase while the engine is running. Removing the oil fill plug while the engine is hot can cause hot oil to spray out of the crankcase and cause severe skin burns. Allow engine oil to cool for several minutes before removing the oil fill plug.
	Always perform maintenance in a well-ventilated area. Fuel and fuel vapours are extremely flammable and can ignite under certain conditions.
	Point the spray gun in a safe direction and pull the trigger to relieve any confined water pressure before carrying out maintenance.

 WARNING	
	Failure to correctly perform periodic maintenance or necessary repairs can cause the pressure washer to malfunction.

 CAUTION	
	Avoid skin contact with engine oil or fuel. Prolonged skin contact with engine oil or fuel can be harmful. Frequent and prolonged contact with engine oil may cause skin cancer. Take protective measures and wear protective clothing and equipment. Wash all exposed skin with soap and water.

NOTICE	
Periodic maintenance intervals vary depending on pressure washer operating conditions. Operating the pressure washer under severe conditions such as sustained high load, high temperature, or unusually wet or dusty environment will require more frequent periodic maintenance. The intervals listed in the maintenance schedule should be treated only as a general minimum guideline. Use only genuine Westinghouse spare parts or others as specified herein. Non-genuine spare parts may be of inferior quality and cause damage to the pressure washer.	

MAINTENANCE SCHEDULE

Following the maintenance schedule is essential to keep the pressure washer in good operating condition. Table 1 provides a summary of routine inspection procedures and simple maintenance tasks that can be performed by someone with mechanical proficiency using commonly available hand tools. Alternatively, an authorised Westinghouse service dealer can carry out this work for a fee.

Table 1 Basic Maintenance Schedule - Owner Performed

Maintenance Item	Before Every Use	After First 20 Hours	After 50 Hours or Every 3 Months *	After 100 Hours or Every 6 Months *
Engine Oil	Check / Add	Change	–	Change ^
Air Filter Elements	Check / Clean		Clean ^	Replace ^
Fuel Strainer	–	–	Check / Clean	–
Fuel Sediment Cup	–	–	Check / Clean	–
Spark Plug	–	–	Check / Adjust	Replace
Spark Arrestor	Check	–	Check / Clean	–
Exterior Surfaces	Check / Clean	–	–	–
Water Inlet Screen	Check / Clean	–	–	Replace
High Pressure Hose	Check	–	–	–
Spray Gun	Check	–	–	–
Spray Nozzles	Check / Clean	–	–	–
Detergent System	Check / Clean	–	–	–
Pressure Pump	Check / Clean	–	–	–

* Whichever occurs first. ^ Service more frequently in dusty conditions.

Table 2 lists the more complicated maintenance tasks that are best performed by a qualified mechanic using specialised tools. It is recommended to engage an authorised Westinghouse service dealer to do this work.

Table 2 Advanced Maintenance Schedule - Authorised Westinghouse Service Dealer Performed

Maintenance Item	After 300 Hours or Every Year *	After 500 Hours or Every 2 Years *	Specification
Engine Idle Speed	Check / Adjust	–	Full Load: 3,600 ± 50 rpm No Load: 3,750 ± 50 rpm
Valve Clearance (Cold Engine)	Check / Adjust	–	Intake Valve 0.08 - 0.12 mm Exhaust Valve 0.13 - 0.17 mm
Combustion Chamber	–	Remove Carbon Build-Up	–

BEFORE ANY MAINTENANCE

1. Always operate or maintain the pressure washer on a level surface.
2. Stop engine if running.
3. Let engine cool for several minutes to allow the crankcase pressure to equalise.
4. Turn off the water supply, point the spray gun in a safe direction and pull the trigger to relieve any confined water pressure, and disconnect the water supply hose from the pressure washer.

MAINTENANCE

ENGINE OIL

Engine Oil Specification

Use premium quality 4-stroke engine oil with an API Service Classification of at least SJ. An SAE multigrade viscosity of 5W-30 or 10W-30 is suitable for use in ambient temperatures of up to 40°C. For temperatures above 40°C, a multigrade viscosity of 10W-40 or 15W-40 is recommended.

NEVER use 2-stroke engine oil either directly in the engine or mixed with the fuel.

Mineral based, semi-synthetic or fully synthetic oils may be used, but different types of oils should not be mixed. The engine oil supplied originally with the pressure washer is a mineral type with SAE 10W-30 viscosity.

Check Engine Oil

NOTICE

Always maintain proper engine oil level. Failure to maintain proper engine oil level can damage the engine.

Always use the specified engine oil. Failure to use the specified engine oil can cause accelerated wear or shorten the life of the engine.

Tools required - None.

Engine oil level should be checked before every use.

1. Use a rag to clean around the oil fill plug & dipstick.
2. Remove oil fill plug & dipstick by unscrewing it anti-clockwise (see Figure 24) and wipe it clean.
3. Re-insert the oil fill plug & dipstick without screwing it into the oil filler neck, remove it and check the oil level indicated.
 - Acceptable Oil Level - Oil is visible on the crosshatches between the H and L lines on the dipstick (see Figure 25).
 - Low Oil Level - Oil is below the L line on the dipstick.

The oil level should ideally be at or close to the H line.

NOTICE

Engine oil capacity is 0.6 L (600 mL). Do not overfill.



Figure 24 Oil Fill Plug and Dipstick

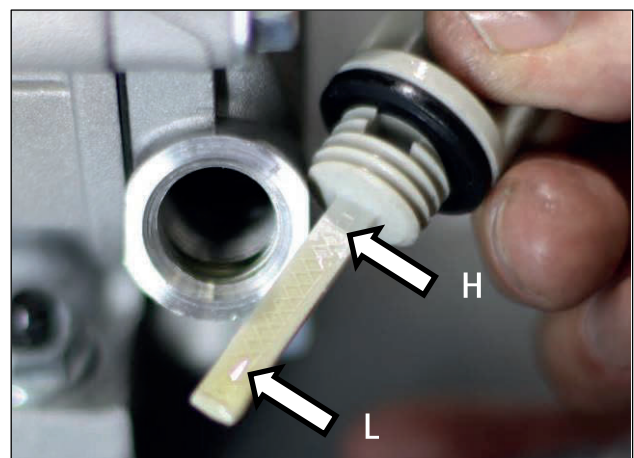

Figure 25 Check Oil Level

Add Engine Oil

Tools required - None.

1. Thoroughly clean around the oil fill plug & dipstick.
2. Remove oil fill plug & dipstick and wipe it clean.
3. Select the proper engine oil as explained in Engine Oil Specification.
4. Using the supplied oil bottle and funnel tip, slowly add engine oil to the engine as shown in Figure 26. Stop frequently to check the level to avoid overfilling.



Figure 26 Add Engine Oil

- Continue to add oil until the oil is at the correct level. (See Check Engine Oil). A simple visual guide is to observe the oil level relative to the bottom lip of the oil filler neck in the engine (into which the oil plug & dipstick is screwed). If the oil reaches the bottom lip, then it's at the high level. If the oil is above the bottom lip and flows out of the hole, then it's too full and the excess must be drained out.

Change Engine Oil

For optimal performance, change the engine oil according to the intervals specified in the maintenance schedule.

NOTE: Change the oil while the engine is warm but not hot. Warm engine oil drains more quickly and thoroughly than cool lubricant. Contact with hot lubricant will cause serious burns.

Tools required - 10 mm spanner and oil drain pan.

- Place oil pan or suitable container underneath the cut-out in the chassis baseplate located below the oil drain plug.
- Use a rag to thoroughly clean around the oil drain plug and also the oil fill plug & dipstick.
- Remove the oil drain plug (see Figure 27). Once removed, place the oil drain plug on a clean surface.
- Remove the oil fill plug & dipstick so that the oil can flow more easily from the oil drain port.
- Allow oil to drain completely. Tilting the pressure washer slightly towards the oil drain hole will help to empty the crankcase.

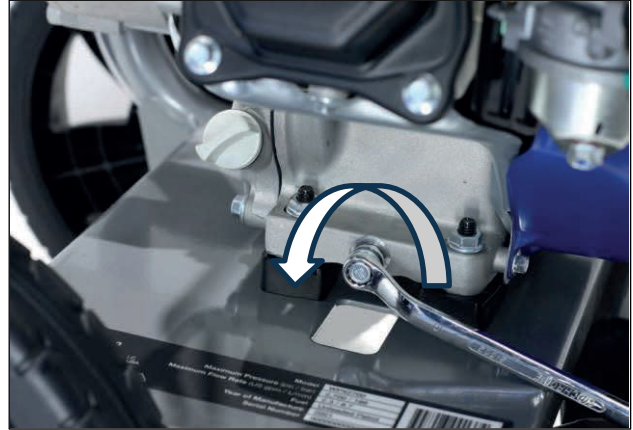

Figure 27 Remove the Oil Drain Plug

- Replace and tighten oil drain plug.
- Fill crankcase with oil following the steps outlined in Add Engine Oil.
- Dispose of used engine oil properly.

An alternative and superior method for draining is to use an oil extractor vacuum pump to remove the used oil via the oil fill plug hole.

NOTICE

Never dispose of used engine oil by dumping the oil into a sewer, on the ground, or into groundwater or waterways. Always be environmentally responsible. Follow the guidelines of the government agencies for proper disposal of hazardous materials. Consult local authorities or reclamation facility.

AIR FILTER

WARNING



Never use fuel or other flammable solvents to clean the air filter. Use only household detergent and warm water or alternatively a non-flammable solvent.

NOTICE

Do not operate the pressure washer without an air filter element or with a damaged air filter element. This will allow dirt to enter the engine and cause accelerated wear, thereby shortening the life of the engine.

The air filter should be cleaned after every 50 hours of use and replaced after every 100 hours of use (or every year, whichever occurs first). These maintenance intervals should be reduced if the pressure washer is operated in a dusty environment.

MAINTENANCE

Clean the Air Filter

Tools required - None.

1. Unscrew the wing nut holding the air filter cover in place and remove the cover (see Figure 28).

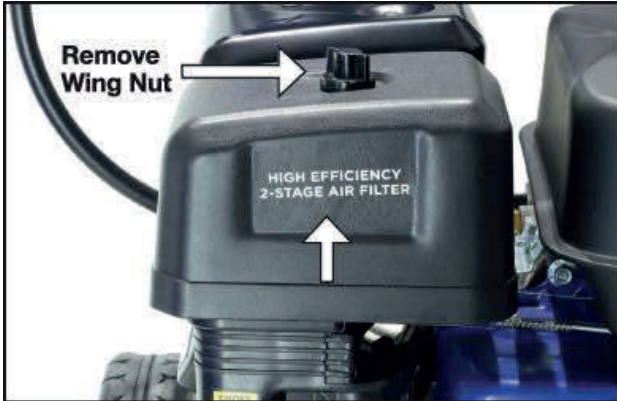

Figure 28 Remove the Air Filter Cover

2. Unscrew the wing nut holding the air filter elements in place and remove the filter elements (see Figure 29).



Figure 29 Remove the Air Filter Elements

3. Carefully remove the foam pre-filter element from around the paper filter element (see Figure 30).



Figure 30 Remove the Air Pre-Filter Element

4. Inspect both air filter elements and replace either if damaged.
5. Clean the paper filter element by tapping it several times on a hard surface to remove loose dirt and then blow compressed air through it from the inside with a pressure not exceeding 200 kPa (30 psi). Do not try to brush or scrape any dirt off the paper filter element as this mechanical action will force the contaminants deeper into the filter media.
6. Clean the foam pre-filter element by washing it in a solution of household detergent and warm water or alternatively in non-flammable solvent. Slowly squeeze the foam in the liquid for a thorough cleaning action. Then remove the foam and squeeze out the excess liquid.

NOTICE

Never twist or tear the air filter element during cleaning or drying. Apply only a slow and firm squeezing action.

7. Rinse the foam pre-filter element by immersing it in fresh water and apply a slow squeezing action. Then remove the foam and squeeze out the excess liquid. Allow to dry thoroughly.

NOTICE

Never dispose of the used cleaning solution or solvent by dumping it into a sewer, on the ground, into groundwater or into a waterway. Always be environmentally responsible. Follow the guidelines of the government agencies for proper disposal of hazardous materials. Consult local authorities or reclamation facility.

8. Coat the foam pre-filter element in clean engine oil and then squeeze out excess oil.
9. Carefully re-fit the foam pre-filter element around the paper filter element.
10. Use a rag to thoroughly clean around the inside of the air cleaner base (still attached to the engine) and the air filter cover. Take care to prevent dirt from entering the carburettor intake in the centre of the air cleaner base.
11. Re-install the air filter elements inside the air filter housing while taking care to ensure that the elements are correctly positioned.
12. Screw down the wing nut atop the air filter elements tightly, re-install the air filter cover, and finally screw down the wing nut atop the cover tightly.

Replace the Air Filter Elements

Follow the procedure above to clean the air filter elements but replace them with new ones instead of cleaning the old ones as described in Steps 7 to 9.

FUEL SYSTEM

Clean the Fuel Strainer

Tools required - None.

Check and clean the fuel strainer after every 50 hours of use or every year, whichever occurs first. It is recommended that this maintenance task also be performed each time when filling with fuel from any source other than directly from a service station bowser.

1. Clean area around the fuel cap with a rag.
2. Remove the fuel cap and set it aside on a clean surface.
3. Remove the fuel strainer by hand from inside the filler hole on top of the fuel tank (see Figure 31) taking care not to tear or otherwise damage the fine mesh screen. Keep the fuel strainer vertical so that any trapped liquid or solids do not spill onto the pressure washer.



Figure 31 Remove the Fuel Strainer

4. Pour the contents of the fuel strainer into a suitable waste receptacle. Low pressure compressed air not exceeding 200 kPa (30 psi) can be used if necessary for blowing onto the outside of the strainer mesh to remove any trapped fine grit.

NOTICE

Never dispose of fuel or fuel contaminants by dumping either of them into a sewer, on the ground, or into groundwater or waterways. Always be environmentally responsible. Follow the guidelines of the government agencies for proper disposal of hazardous materials. Consult local authorities or reclamation facility.

5. Re-install the fuel strainer by hand inside the filler hole on top of the fuel tank. Make sure it is fully inserted into the opening and that the two notches in its rim align with the notches in the rim of the fuel tank filler neck. (See Figure 32).

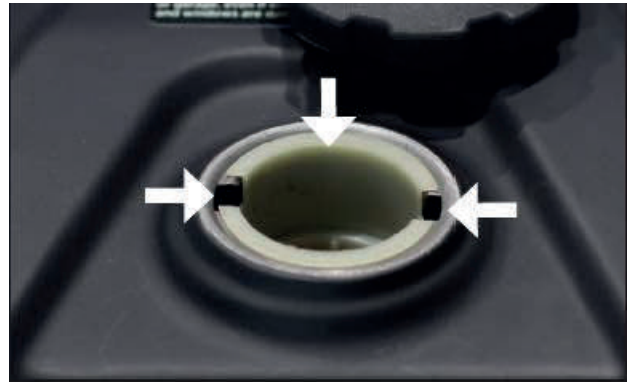

Figure 32 Re-install the Fuel Strainer

6. Re-install the fuel cap.

Fuel Sediment Cup

Tools required – 10 mm spanner.

1. Turn off the pressure washer and let it cool for several minutes if it has been running.
2. Move the pressure washer to a level surface.
3. Move the fuel valve lever to the OFF position.
4. Clean the exterior of the fuel valve and sediment cup with a rag.
5. Unscrew the sediment cup anti-clockwise (see Figure 33) taking care to hold it with one hand to prevent it from dropping onto the ground and spilling its contents. Remove also the O-ring carefully (see Figure 34) by hand.
6. Pour the contents of the fuel sediment cup into a suitable waste receptacle and then use a rag to wipe it out clean and dry.

NOTICE

Never dispose of fuel or fuel contaminants by dumping either of them into a sewer, on the ground, or into groundwater or waterways. Always be environmentally responsible. Follow the guidelines of the government agencies for proper disposal of hazardous materials. Consult local authorities or reclamation facility.

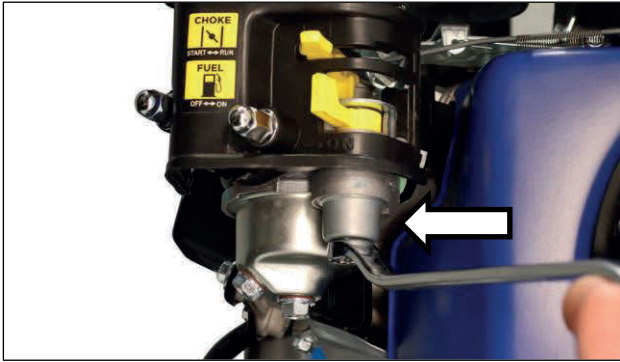

Figure 33 Remove Fuel Sediment Cup



Figure 34 Fuel Sediment Cup and O-ring

7. Re-install the O-ring and fuel sediment cup by hand taking care to ensure the O-ring is properly seated around its perimeter up against the inside of the fuel valve (see Figure 35). Finish tightening the fuel sediment cup by screwing it clockwise with a spanner.

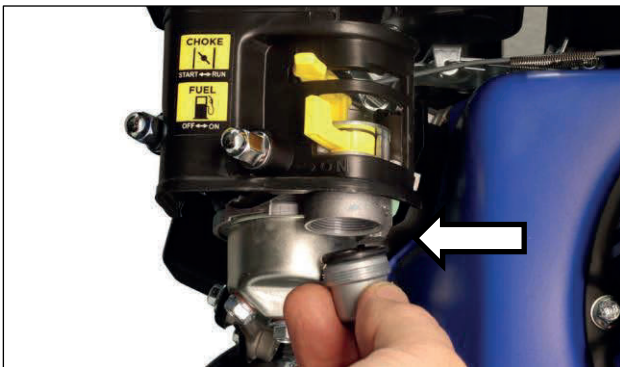

Figure 35 Re-install Fuel Sediment Cup and O-ring

8. Turn the fuel valve to the ON position and check for any leaks around the threaded joint where the fuel sediment cup screws into the fuel valve. Tightening the fuel sediment cup a bit more with a spanner should seal off any normal leak. If this doesn't work, repeat steps 4 to 8 above taking particular care with installation of the O-ring.

9. After confirming there are no fuel leaks, turn the fuel valve to the OFF position.

Drain the Fuel

Occasionally it may be necessary to drain all of the fuel out of the pressure washer. For example, to remove contaminated or stale fuel or to prepare the pressure washer for transport or storage.

Tools required – 10 mm spanner, funnel and fuel storage container.

1. Move the fuel valve lever to the ON position.
2. Loosen the fuel tank cap, but leave it in situ covering the fuel tank filler opening for safety.
3. Position the funnel and fuel storage container under the carburettor drain screw and then remove the screw by turning it anti-clockwise with the spanner as shown in Figure 36.



Figure 36 Remove the Carburettor Drain Screw

4. Carefully drain the fuel into the storage container. Take care to wipe up any spills immediately.
5. When all of the fuel has been drained out, reinstall the carburettor drain screw by turning it clockwise by hand first, and then finish tightening it with the spanner. Move the funnel, storage container and any fuel soaked rags away from the pressure washer. It is preferable to consume the fuel in another engine-powered device straight away or dispose of it properly rather than storing it for a long time with fuel stabiliser for later re-use.
6. Move the fuel valve lever to the OFF position and then clean the fuel sediment cup.
7. Tighten the fuel tank cap closed.

NOTICE

Never dispose of fuel or fuel contaminants by dumping either of them into a sewer, on the ground, or into groundwater or waterways. Always be environmentally responsible. Follow the guidelines of the government agencies for proper disposal of hazardous materials. Consult local authorities or reclamation facility.

SPARK PLUG

Tools required – 13/16 inch spark plug socket wrench, spark plug gap tool or feeler gauge and wire brush.

The spark plug should be checked and cleaned after every 50 hours of use and replaced after 100 hours of use or every year, whichever occurs first.

8. Remove the spark plug boot by firmly pulling it directly away from the engine (see Figure 37).



Figure 37 Removal of Spark Plug Boot

NOTICE

Never apply any side load or move the spark plug laterally when removing the spark plug. Applying a side load or moving the spark plug laterally may crack and damage the spark plug insulator.

9. Clean area around the spark plug with a rag.
10. Use a spark plug socket wrench to remove the spark plug from the cylinder head by unscrewing it anti-clockwise (see Figure 38).

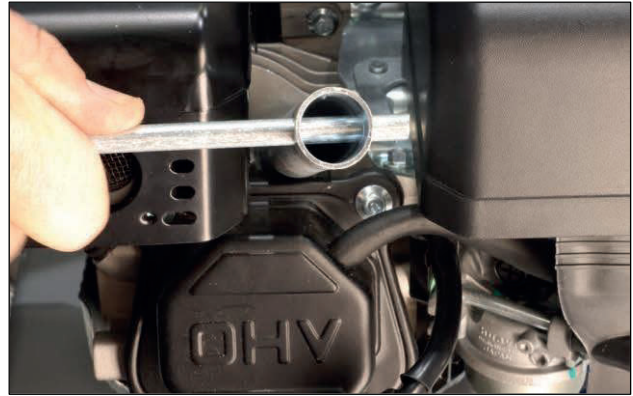

Figure 38 Remove Spark Plug

11. Place a clean rag over the opening created by removal of the spark plug to make sure no dirt can get into the combustion chamber.

12. Inspect the spark plug for:

- Cracked or chipped insulator; replace the spark plug.
- Excessive wear of the electrodes; replace the spark plug.
- Excessive carbon or oil fouling of the electrodes; clean the electrodes with a wire brush or replace the spark plug.
- Spark plug gap within the acceptable limits of 0.70 – 0.80 mm or 0.028 – 0.031 inch (see Figure 39); after cleaning with a wire brush, check using a spark plug gap tool or feeler gauge and adjust by carefully bending the ground electrode. Always check the gap of a new spark plug before installing it.

When replacing the spark plug, use only a Torch F7RTC or equivalent spark plug such as Bosch WR5DC, Denso W22EPR-U, NGK BPR7ES or Champion RN7YC.

NOTICE

Use only the recommended spark plug (Torch F7RTC or equivalent). The use of a non-recommended or incorrectly installed spark plug can result in damage to the engine.

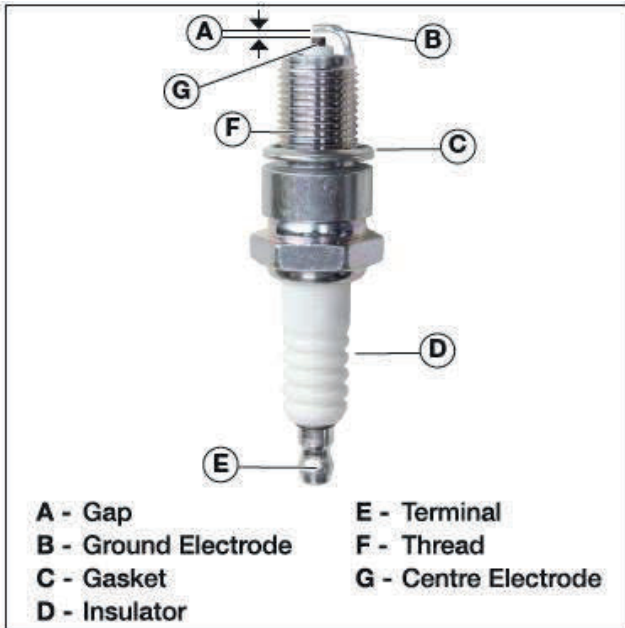

Figure 39 Spark Plug

13. Re-install the spark plug by following the steps outlined below:
 - a. Carefully insert the spark plug back into the cylinder head. Hand screw the spark plug clockwise until it bottoms out (seats).
 - b. Use a spark plug socket wrench to finish tightening the spark plug. If re-installing a used spark plug, tighten 1/8 to 1/4 of a turn after the spark plug seats. If installing a new spark plug, tighten 1/2 of a turn after the spark plug seats.
 - c. Replace the spark plug boot, making sure the boot fully engages onto the spark plug's terminal.

Spark Arrestor

Tools required – 8 mm spanner and wire brush.

Check and clean the spark arrester after every 50 hours of use or 3 months.

1. Unscrew the four bolts affixing the heat shield to the muffler and remove the heat shield. (See Figure 40).

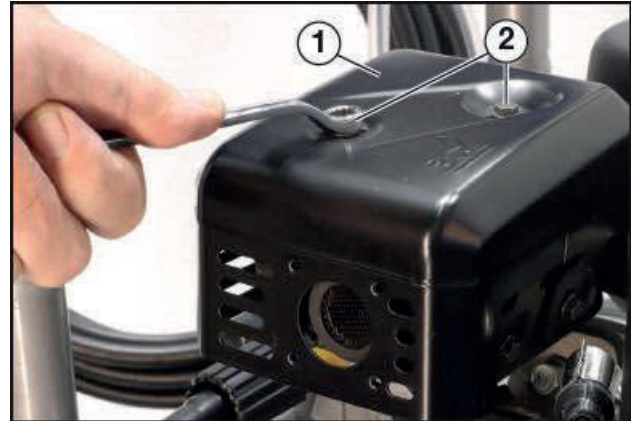

1. Heat Shield
2. Bolt

Figure 40 Remove the Muffler Heat Shield

2. Unscrew the two bolts affixing the spark arrester screen to the muffler and remove the screen. (See Figure 41).

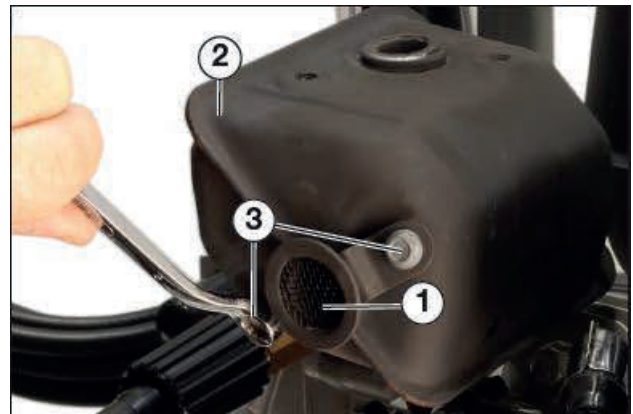

1. Spark Arrester Screen
2. Muffler
3. Bolt

Figure 41 Remove the Spark Arrester Screen

3. Using a wire brush, remove any carbon deposits that may have collected on the spark arrester screen. If the screen shows signs of wear such as rips, tears or large openings, it should be replaced.
4. Re-install the spark arrester screen and heat shield in the reverse order of removal as described above.

CLEAN THE PRESSURE WASHER

The pressure washer should be kept clean and dry at all times to ensure its reliable and safe operation. This should be checked each time before using the pressure washer.

Use a damp cloth which has been soaked in a mixture of household or pressure washer detergent and warm water and then wrung out to remove excess liquid. Wipe the exterior surfaces of the pressure washer clean and then repeat with a damp cloth which has been rinsed in clean water and wrung out. Finish by wiping off all moisture with a dry cloth. Do not use abrasive or solvent cleaners.

A soft, non-metallic bristle brush or a vacuum cleaner can be used to loosen and remove any built-up dirt, mud or other debris. Low pressure compressed air not exceeding 200 kPa (29 psi) can also be used to blow off any dirt or dust.

NOTICE

Never use sprayed-on water to clean the pressure washer. Water may enter the fuel, air intake or exhaust systems and damage the engine.

WATER SYSTEM

Water Inlet Screen

NOTICE

Do not operate the pressure washer without a properly functioning water inlet screen installed. Otherwise, the water pump may be damaged.

The water inlet screen is a small plastic component, and its filter mesh is necessarily quite thin. Take care during the maintenance procedure not to damage it.

Tools required – Small flat blade screwdriver.

1. Stop the pressure washer and let it cool down if it has been running.
2. Turn off the water supply and disconnect the water supply hose from the inlet connection.
3. Point the spray gun in a safe direction and pull the trigger to relieve any confined water pressure.
4. Carefully pry out the water inlet screen as shown in Figure 42.

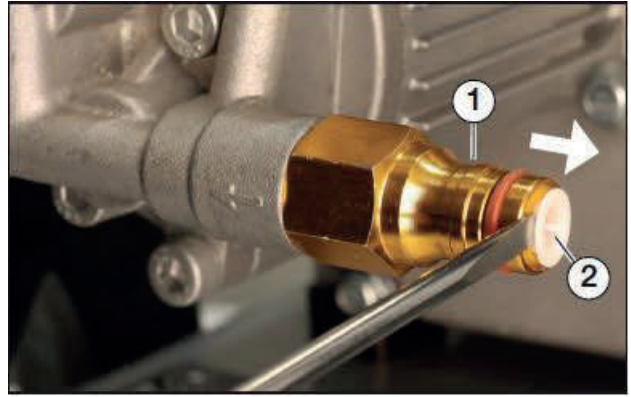

1. Water Inlet Connection
2. Water Inlet Screen

Figure 42 Remove the Water Inlet Screen

5. Inspect the water inlet screen for debris or damage. Clean the filter mesh by backwashing it with water from the outside to the inside. If damaged, the water inlet screen should be replaced.
6. Re-install the water inlet screen by pushing it fully into the water inlet connection by hand.

High Pressure Hose

1. Stop the pressure washer if it has been running.
2. Turn off the water supply and disconnect the water supply hose from the inlet connection.
3. Point the spray gun in a safe direction and pull the trigger to relieve any confined water pressure.
4. Disconnect the high pressure hose by unscrewing it from the water pump outlet and the spray gun inlet.
5. Check the O-ring on each of the two pressure hose threaded couplings. Replace any O-ring that is cracked, split or otherwise damaged.
6. Check the high pressure hose for any leaks, cuts, abrasions, kinks or bulging cover and also check the couplings for any damage or movement (relative to the hose). Replace the hose assembly if it has any of these faults; do not attempt to repair it. Use only a genuine Westinghouse high pressure hose assembly replacement with a pressure rating equal to or greater than that of the pressure washer.
7. Lubricate the O-rings with water or silicone lubricant and then re-connect the high pressure hose to the water pump outlet and spray gun inlet. Tighten the connections firmly by hand.

MAINTENANCE

Spray Gun

1. Stop the pressure washer if it has been running.
2. Turn off the water supply and disconnect the water supply hose from the inlet connection.
3. Point the spray gun in a safe direction and pull the trigger to relieve any confined water pressure.
4. Unscrew the lance from the spray gun outlet.
5. Check the two O-rings on the spray gun / lance threaded coupling. Replace any O-ring that is cracked, split or otherwise damaged.
6. Release the trigger lock on the spray gun by rotating it into its stowed position on the rear of the trigger as shown in Figure 11. Note: Push the trigger forwards for ease of releasing the trigger lock.
7. Test the trigger by pulling it backwards towards the pistol-grip handle. Check that the trigger springs back to its original position when released. If faulty, replace the spray gun.
8. Test the trigger lock by cycling it between the SAFETY OFF and SAFETY ON positions as shown in Figure 11. Check that the trigger lock remains securely in place when in the SAFETY ON position such that it prevents the trigger from being pulled. If faulty, replace the spray gun.
9. Lubricate the O-rings with water or silicone lubricant and then re-connect the lance to the spray gun outlet as shown in Figure 9. Tighten the connection firmly by hand.
10. Apply the trigger lock on the spray gun by rotating it away from the trigger and locking it into position within the detent on the hand grip as shown in Figure 11. Note: Push the trigger forwards for ease of applying the trigger lock.

Spray Nozzles

1. Stop the pressure washer if it has been running.
2. Turn off the water supply and disconnect the water supply hose from the inlet connection.
3. Point the spray gun in a safe direction and pull the trigger to relieve any confined water pressure.
4. Apply the trigger lock on the spray gun by rotating it away from the trigger and locking it into position within the detent on the hand grip as shown in Figure 11. Note: Push the trigger forwards for ease of applying the trigger lock.

5. Pull back the collar on the lance's quick connect coupling to its limit and withdraw the installed spray nozzle by pulling it away from the lance as shown in Figure 21. Then release the locking collar.
6. Clean the spray nozzle by backwashing the orifice with water and removing any obstructions using the supplied nozzle cleaning tool as shown in Figure 43. Repeat this step for the other nozzles, if required, and then store them back in their respective marked locations on the nozzle and hose holder.

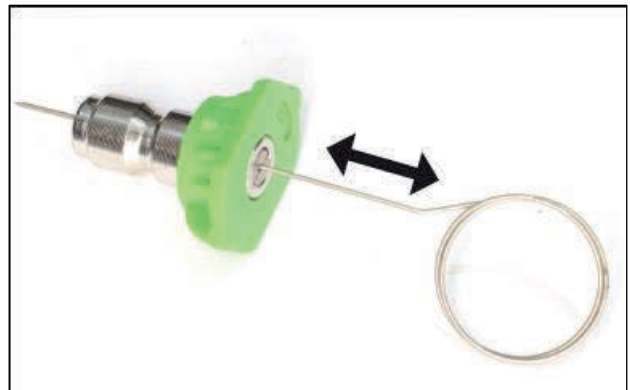

Figure 43 Spray Nozzle Orifice Cleaning

7. Select the desired spray nozzle for the next cleaning application.
8. Pull back the collar on the lance's quick connect coupling to its limit and insert the spray nozzle fully as shown in Figure 12. Then pull the collar forward if it has not already snapped back forward by spring action. Tug on the spray nozzle to verify that it is securely locked into the coupling.
9. Release the trigger lock on the spray gun by rotating it into its stowed position on the rear of the trigger as shown in Figure 11. Note: Push the trigger forwards for ease of releasing the trigger lock.

NOTE: The nozzle cleaning tool is fitted with a protective sheath on its pointed end. Remove the sheath before using the tool and replace it afterwards.

Detergent System

1. Stop the pressure washer and let it cool down if it has been running.
2. Turn off the water supply and disconnect the water supply hose from the inlet connection.
3. Point the spray gun in a safe direction and pull the trigger to relieve any confined water pressure.

4. To clean the detergent tank, if required, pull off the detergent tube from the barbed fitting on the bottom of the tank as shown in Figure 44 and flush the tank clean with running water from a garden hose.
5. Check that the breather hole in the top of the detergent tank cap is unobstructed. Clean it with running water and use the nozzle cleaning tool if necessary.

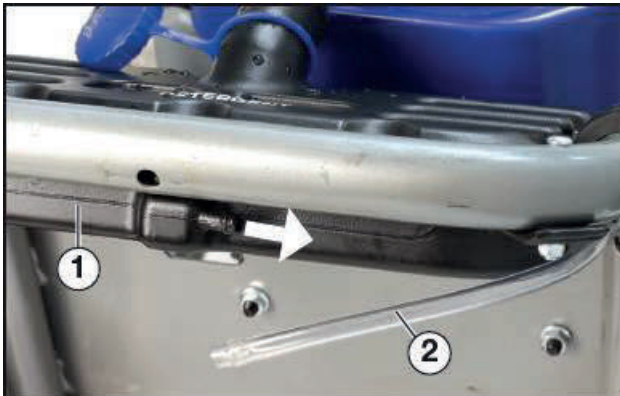

1. Detergent Tank
2. Detergent Tube

Figure 44 Disconnect the Tube from the Detergent Tank

6. Check the detergent tube for leaks, cuts, kinks or blockages. The tube should fit tightly onto the barbed fittings at the bottom of the detergent tank and the top of the water pump. Replace the tube if damaged.

To clean the detergent tube, if required, pull both ends off from their barbed fittings and flush the tube clean with running water from a garden hose.

7. A non-return check valve ball and spring are installed inside the barbed tube fitting atop the water pump, whose function it is to prevent high pressure water from flowing backwards through the detergent tube and tank. The check valve ball can become stuck after a period of storage due to dried detergent or mineral deposits and this can result in poor or nil flow of detergent. The check valve ball can be freed, if required, as follows:
 - a. Pull the detergent tube off the barbed fitting on the water pump.
 - b. Select a tool object such as a pin punch or hex key with a diameter of less than 3 mm and a length of at least 25 mm.
 - c. Gently lower the tool vertically into the orifice of the barbed fitting as shown in Figure 45 until resistance is felt upon contact inside with the check valve ball.

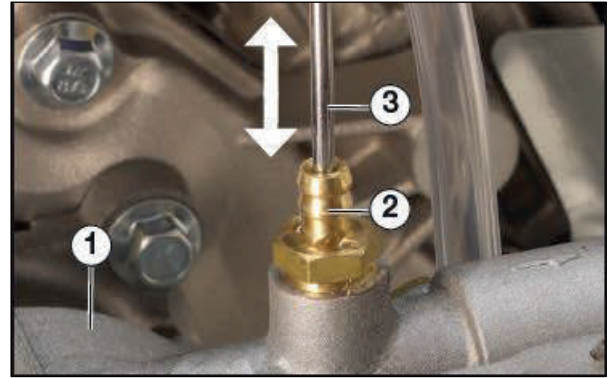

1. Pump
2. Barbed Tube Fitting
3. Tool

Figure 45 Unblock the Detergent Check Valve Ball

- d. Using the minimum amount of force, press the tool down further vertically by no more than 5 mm and then release it whereupon the ball should spring back to its upper limit. Repeat this step several times until the ball moves down and springs back freely.
- e. Re-connect the detergent tube onto the barbed fittings.

Water Pump

Tools required – 10 mm spanner or socket wrench.

1. Stop the pressure washer and let it cool down if it has been running.
2. Turn off the water supply and disconnect the water supply hose from the inlet connection.
3. Point the spray gun in a safe direction and pull the trigger to relieve any confined water pressure.
4. The water pump is pre-filled with oil and sealed at the factory. It requires no regular maintenance other than external cleaning and visual inspection for oil leaks.
5. The procedure to replace the water pump, if necessary, is as follows:
 - a. Disconnect the water supply hose, high pressure hose and detergent tube from the water pump.
 - b. Using a 10 mm spanner or socket wrench, remove the four bolts that affix the water pump to the engine as shown in Figure 46 and then pull the pump off from the engine crankshaft entirely.

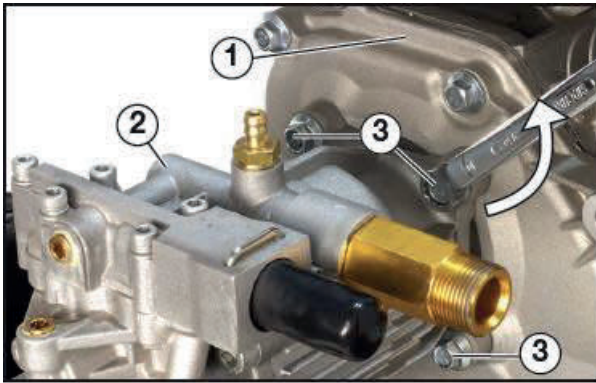

1. Engine
2. Pump
3. Pump Mounting Bolt

Figure 46 Remove the Water Pump

- c. Clean the protruding stub of the engine crankshaft and the shaft key with a rag and inspect for damage. If OK, apply a thin layer of grease onto the crankshaft stub and shaft key. (See Figure 47).
- d. Slide the replacement water pump onto the engine crankshaft taking care to align the crankshaft key with the matching keyway inside the water pump input shaft.

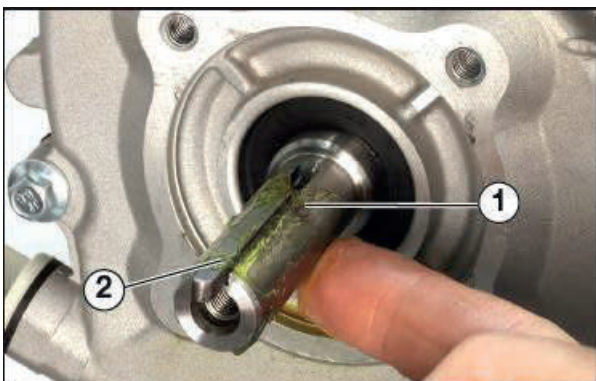

1. Engine Crankshaft PTO Stub
2. Crankshaft Key

Figure 47 Engine Crankshaft PTO Stub and Key

- e. Rotate the water pump as required so that its four mounting holes align with those on the rear of the engine crankcase.
- f. Apply a small amount of tread lock adhesive onto the pump mounting bolts and then reinstall them with a tightening torque of 15 Nm in a crosswise sequence.
- g. Re-connect the detergent tube.

LONG-TERM STORAGE

⚠ WARNING



Never store a pressure washer with fuel in the tank indoors or in a poorly ventilated area where the fumes can come into contact with an ignition source such as: a pilot light of a stove, water heater, clothes dryer or any other gas appliance, or a spark from an electric appliance.

NOTICE

Fuel stored for as little as 30 days can go bad, causing gum, varnish and corrosive build-up in fuel lines, fuel passages and the engine. This corrosive build-up restricts the flow of fuel, preventing an engine from starting after a prolonged period of storage.

Some of the most commonly experienced faults with pressure washers are directly attributable to stale fuel. Such faults are not covered by the pressure washer's warranty.

The pressure washer should be run at least once per month. If this is not possible, the pressure washer should be prepared for long-term storage as described hereunder.

Proper care should be taken to prepare the pressure washer for any long-term storage. This will protect the pressure washer's function and appearance and will make it easier to start when next required.

Storage for 1 - 3 Months

1. Add a proprietary fuel stabiliser to the fuel tank and then add fresh fuel up to the tank's maximum capacity. Follow the manufacturer's recommendation for correct ratio of stabiliser to fuel.
2. Carry out any necessary scheduled maintenance or repairs.
3. Follow the procedure described in After Each Use.

Storage for Greater Than 3 Months

1. Carry out any necessary scheduled maintenance or repairs.
2. Change the engine oil if it wasn't done in the previous step.
3. Follow the procedure described in Steps 1 to 13 of After Each Use.

4. Remove the spark plug (see SPARK PLUG Maintenance) and pour a tablespoon of clean engine oil into the spark plug opening. While placing a clean rag over the spark plug opening, slowly pull the recoil starter handle to rotate the engine several times. This will distribute the oil and protect the cylinder wall from corrosion during storage.
5. Re-install the spark plug (see SPARK PLUG Maintenance).
6. Drain the fuel (see Drain the Fuel).
7. Wipe down the pressure washer with a rag or chamois.
8. Store the pressure washer in a clean, dry and well ventilated place that is not subject to freezing temperatures.

NOTICE

Do not pollute the environment by improper or illegal disposal of the waste fluids. Dispose of these hazardous items only at an authorised waste collection / recycling facility.

Do not pollute the environment by improper or illegal disposal of the pressure washer either as a whole or in parts. Take the unwanted unit or components to your local recycling centre instead. The pressure washer is made almost entirely of metals that can be recycled.

Remove from Storage

Follow the normal procedures for pre-operation checks and starting (see PREPARE FOR OPERATION).

Use only fresh fuel to re-fill the tank, if necessary, rather than re-using the old fuel.

If oil was inserted into the cylinder prior to storage, the exhaust may smoke for a short while after starting the pressure washer; this is normal and will cease within a minute or so of running time.

DISMANTLE AND DISPOSE

There is no requirement for the pressure washer to be dismantled during normal operation other than for major repair, overhaul or prior to final disposal at the end of its service life.

Dismantling should only be carried out by a mechanically proficient person with access to proper tools or alternatively by your authorised Westinghouse service dealer for a fee.

Before dismantling:

1. Stop the pressure washer.
2. Drain the engine oil.
3. Drain the fuel.

TROUBLESHOOTING

⚠ WARNING



Before attempting to service or troubleshoot the pressure washer, the owner or service technician must first read and understand this instruction manual and comply with all safety instructions. Failure to follow all instructions may result in conditions leading to voiding of the product warranty, serious personal injury, property damage or even death.

PROBLEM	POTENTIAL CAUSE	SOLUTION
Engine will not start or starts and runs rough.	Out of fuel.	Check fuel level and add fuel if necessary.
	Low oil level.	Check oil level and add oil if necessary.
	Engine switch is in the OFF position.	Turn the engine switch to the ON position.
	Fuel valve lever is in the OFF position.	Move the fuel valve lever to the ON position.
	Engine is not choked (if cold).	Move the choke lever to the START position.
	Engine is over choked (if hot).	Move the choke lever to either mid-way between the START and RUN positions or fully to the RUN position.
	Entrapped water pressure inside the machine.	Squeeze the spray gun trigger to release the pressure.
	Fuel is stale, contaminated with water or other foreign substance, or is the wrong type.	Drain fuel and refill with fresh fuel of the correct type. Then clean the fuel sediment cup.
	Spark plug boot is not properly connected onto spark plug terminal.	Push spark plug boot firmly onto spark plug.
	Spark plug is dirty or faulty.	Clean or replace spark plug.
	Air filter is dirty or blocked.	Check air filter and clean or replace if necessary.
	Spark arrestor is dirty or blocked.	Check spark arrestor and clean if necessary.
	Pressure pump is faulty.	Repair or replace water pump.
If above possible causes are checked and eliminated, pressure washer may be faulty.	Take pressure washer to an authorised Westinghouse service dealer.	

TROUBLESHOOTING

PROBLEM	POTENTIAL CAUSE	SOLUTION
Engine stops during operation.	Out of fuel.	Check fuel level and add fuel if necessary.
	Low oil level.	Check oil level and add oil if necessary.
	Engine switch is in the OFF position.	Turn the engine switch to the ON position.
	Fuel valve lever is in the OFF position.	Move the fuel valve lever to the ON position.
	Fuel is stale, contaminated with water or other foreign substance, or is the wrong type.	Drain fuel and refill with fresh fuel of the correct type. Then clean the fuel sediment cup.
	Spark plug boot is not properly connected onto spark plug terminal.	Push spark plug boot firmly onto spark plug.
	Pressure pump is faulty.	Repair or replace water pump.
	If above possible causes are checked and eliminated, pressure washer may be faulty.	Take pressure washer to an authorised Westinghouse service dealer.
Detergent will not dispense with water.	A high pressure washing spray nozzle is installed.	Replace with the black (60°) low-pressure detergent spray nozzle.
	Spray nozzle is obstructed.	Clean the spray nozzle.
	Out of detergent.	Check detergent level and add detergent if necessary.
	Detergent is too viscous.	Dilute detergent with water.
	Detergent tank, detergent tank cap breather hole or outlet hose barb clogged.	Clean detergent tank, detergent tank cap breather hole and outlet hose barb.
	Detergent tube not tightly fitted onto one or both hose barbs.	Install tube securely onto both hose barbs.
	Detergent tube clogged, kinked or damaged.	Clean, re-route or replace detergent tube.
	Detergent non-return check valve ball clogged.	Free the check valve ball.
	If above possible causes are checked and eliminated, pressure washer may be faulty.	Take pressure washer to an authorised Westinghouse service dealer.

TROUBLESHOOTING

PROBLEM	POTENTIAL CAUSE	SOLUTION
Pressure washer will not spray any water or will spray water with insufficient or unsteady flow rate or pressure.	Spray gun trigger not actuated, i.e. the spray gun is closed.	Disengage the trigger safety lock and squeeze the spray gun trigger fully.
	The black (60°) low-pressure detergent spray nozzle is installed.	Replace with a high pressure washing spray nozzle.
	Water supply not turned on sufficiently or at all.	Turn on the water supply fully.
	Water supply hose clogged, kinked or damaged.	Clean, re-route, repair or replace the water supply hose.
	Water supply hose connection to the water pump is leaking water or drawing air.	Check and tighten the water supply connection fittings. Squeeze the spray gun trigger continuously to purge any entrapped air until the spray water discharge is steady.
	Nil or inadequate water supply flow rate or pressure.	Increase the water supply flow rate or pressure.
	Water supply hose is too long or too small in diameter causing excessive pressure drop and flow resistance.	Shorten the length or increase the diameter of the water supply hose.
	Water supply inlet screen is obstructed.	Clean the water supply inlet screen.
	High pressure water connections downstream from the water pump are leaking.	Check and tighten the high pressure water connections. Check the coupling O-rings and replace if damaged.
	High pressure hose clogged, kinked or damaged.	Clean, re-route, repair or replace the high pressure hose.
	Spray gun, lance or spray nozzle is obstructed.	Disconnect the spray gun, lance and spray nozzle. Check each component for internal obstruction and clean as required.
	Spray gun is faulty.	Check the spray gun by testing through-flow with a garden hose or low pressure (≤ 200 kPa) compressed air whilst its trigger is squeezed. Replace spray gun if faulty.
	Pressure pump is faulty.	Repair or replace water pump.
If above possible causes are checked and eliminated, pressure washer may be faulty.	Take pressure washer to an authorised Westinghouse service dealer.	

TROUBLESHOOTING

PROBLEM	POTENTIAL CAUSE	SOLUTION
Water is ejected from the thermal relief valve while engine is running and the spray gun trigger is closed for an extended period, i.e. idling without water spraying.	This is normal operation to protect the water pump from overheating.	No fault.
Water is ejected from the thermal relief valve while engine is running, and the spray gun trigger is open for water spraying.	The water supply temperature is too high.	Provide cooler water supply with temperature below 40°C.
	Thermal relief valve is faulty.	Replace thermal relief valve or water pump.
	If above possible causes are checked and eliminated, pressure washer may be faulty.	Take pressure washer to an authorised Westinghouse service dealer.

SPECIFICATIONS

	PARAMETER	WPX3400
ENGINE	Type	1-Cylinder, 4-Stroke, Overhead Valve, Air Cooled
	Displacement (cm ³)	212
	Speed (rpm)	3,600
	Oil Capacity (mL)	600
	Oil Viscosity	SAE 10W-30
	Low Oil Shutdown	Yes
	Spark Plug	Torch F7RTC
	Spark Plug Gap (mm)	0.60 - 0.80
	Fuel	Unleaded Petrol ‡ (91, 95 or 98 RON)
	Fuel Tank Capacity (L)	3.3
	Starting Method	Recoil
	WATER PUMP AND ACCESSORIES	Pump Type
Maximum Pressure (bar / psi)		234 / 3,400
Maximum Flow Rate (L/min)		9.84
Detergent Capacity (L)		1.9
Detergent Dilution Ratio		1:20 (Detergent to Water)
Hose Length (m)		10.7
Spray Gun		Trigger Control with Safety Lock and 533 mm Steel Lance
Quick Connect Nozzles		0°, 15°, 25° & 40° Wash 60° Detergent
DIMENSIONS AND WEIGHT	Width (mm)	535
	Depth (mm)	495
	Height (mm)	990
	Weight - Wet (kg)	28

‡ Ethanol blends such as E10 are not recommended.

WPX3400 WIRING DIAGRAM

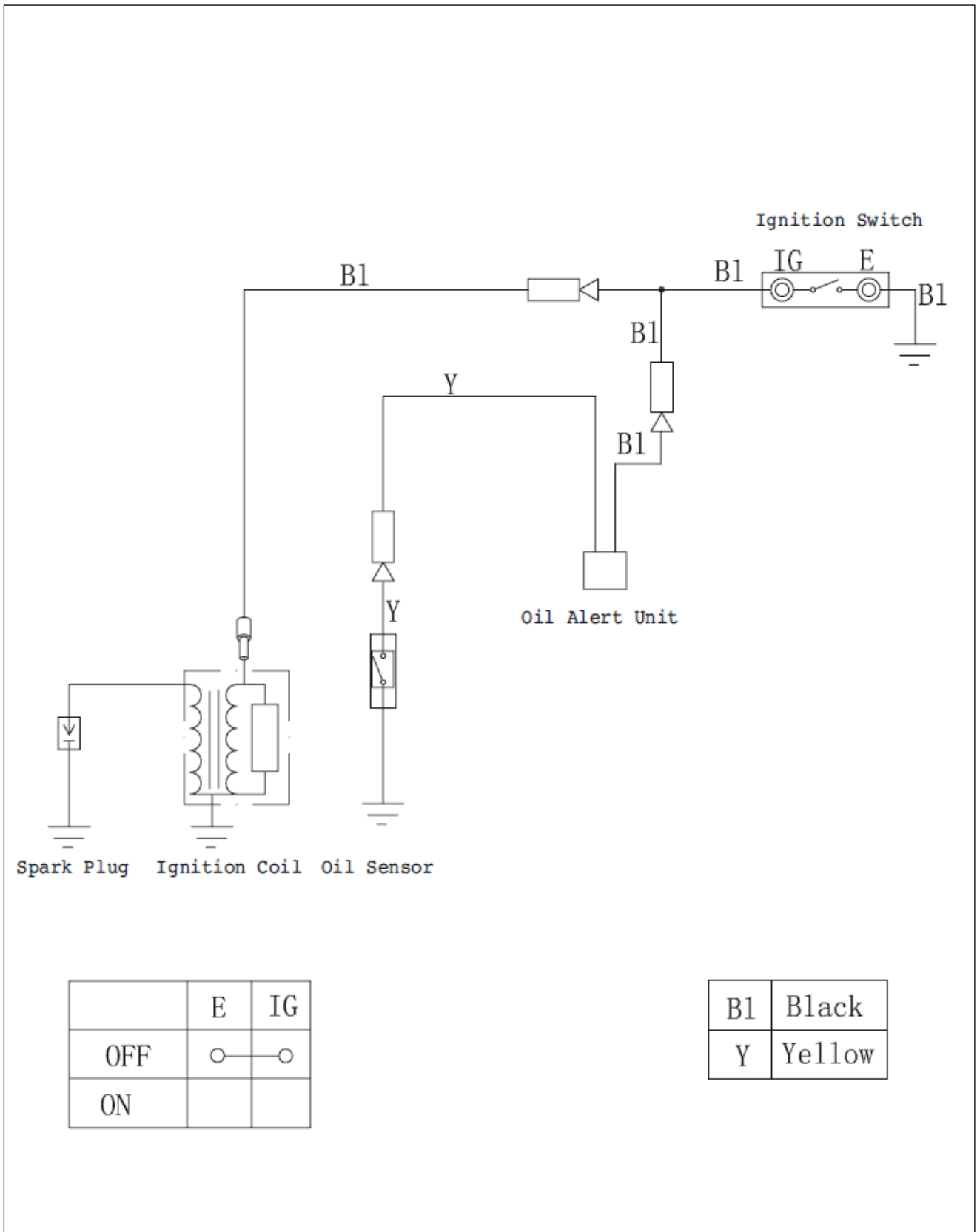

WARRANTY

WARRANTY AGAINST DEFECTS

Proof of Purchase

It is recommended that you keep a copy of the original tax invoice for your records.

Warrantor

Name: Westinghouse Outdoor Power Equipment (ABN 21101370085)
Address: 19 Corymbia Place
Parkinson, 4115, Australia
Phone: 1800 453 626
Email: info@wpowerreq.com.au
Web: westinghouseoutdoorpower.com.au

Warranty Conditions

Westinghouse Outdoor Power Equipment (the "Company") warrants that its domestic portable pressure washers (the "Goods") shall be free from defects in material and workmanship for a period of two (2) years from the date of original sale (hereinafter the "Warranty Period") in normal domestic applications such as personal, residential household or recreational use.

A Warranty Period of ninety (90) days shall apply in commercial, industrial or rental applications or other business-related use. Goods sold to a Consumer with an Australian Business Number shall be deemed as being used in a commercial application.

The Warranty Period is continuous from the date of original sale and does not restart upon the repair or replacement of the Goods or any part thereof. Upon return – transportation charges prepaid by the Consumer – to the Company's or its nominated dealer's premises within the Warranty Period, the Company shall repair or replace, at its option, any Goods which it determines to contain defective material or workmanship, and shall return said Goods to the Consumer free-on-board (FOB) at the Company's or agent's premises. The repair or replacement work will be scheduled and performed according to the Company's normal work flow and availability of replacement parts.

The Company shall not be obligated, however, to repair or replace Goods which have been: repaired by others; abused; improperly installed, operated, maintained, repaired, transported or stored; not serviced to schedule using genuine spare parts; altered or otherwise misused or damaged in any way.

The Company shall not be responsible for any diagnosis, communication, dismantling, packing, handling, freight, and reassembly or reinstallation charges.

Freight damage, pre-delivery service, normal operating adjustments, preventative maintenance service, consumable items, cosmetic damage, corrosion, erosion, normal wear and tear, performance, merchantability, and fitness for a particular purpose are not covered under this Warranty. Consumable items include batteries, filters, fuel, lubricants and spark plugs.

The Company shall not be liable for any repairs, replacements, or adjustments to the Goods or any costs of labour performed by the Consumer or others without the Company's prior written approval.

To the extent permissible by law and notwithstanding any other clause in these Warranty Conditions, the Company excludes all liability whatsoever to the Consumer arising out of or in any way connected with a contract for any consequential or indirect losses of any kind howsoever arising and whether caused by breach of statute, breach of contract, negligence or other tort.

The Company's liability will be limited to, in the case of products, the replacement of the products, the supply of equivalent products or the payment of the cost of replacing the products or of acquiring equivalent products or, in the case of services, the supply of the services again or the payment of the cost of having the services supplied again. The choice of remedy will be at the discretion of the Company and the Consumer acknowledges that this limitation of liability is fair and reasonable.

This Warranty is available only to the original Consumer bearing the original tax invoice from the Company or one of its authorised dealers as proof of purchase. Goods purchased from any other party such as a private seller, auction house, eBay seller, etc. are not covered by this Warranty.

Our Goods come with guarantees that cannot be excluded under the Australian Consumer Law. You are entitled to a replacement or refund for a major failure and compensation for any other reasonably foreseeable loss or damage. You are also entitled to have the Goods repaired or replaced if the Goods fail to be of acceptable quality and the failure does not amount to a major failure.



Westinghouse Outdoor Power Equipment
19 Corymbia Place
Parkinson QLD 4115 Australia

© 2024 All rights reserved. Content may change without notice.
™ and Westinghouse are trademarks of Westinghouse Electric Corporation
used under license by Westinghouse Outdoor Power Equipment.

2024-10-10